



DCRACK

DCRACK
User Guide

July 2025

BITMAIN

BITMAIN TECHNOLOGIES INC.

Content

| | |
|---|----|
| Declaration | 6 |
| 1 About This Document | 6 |
| 1.1 Application Scope..... | 6 |
| 1.2 Product Introduction..... | 8 |
| 1.3 Intended Audience | 8 |
| 1.4 Use of Manual | 9 |
| 1.5 Symbol Conventions..... | 9 |
| 2 Safety Description | 10 |
| 2.1 General Safety Instructions..... | 10 |
| 2.2 All Safety Instructions | 10 |
| 2.3 Electrical Safety..... | 12 |
| 2.4 Mechanical Safety | 13 |
| 2.5 Operation Safety | 13 |
| 2.6 Others | 13 |
| 3 System Composition and System Operation Principles..... | 16 |
| 3.1 System Overview..... | 16 |
| 3.2 System Composition..... | 16 |
| 3.3 System Operation Principles..... | 17 |
| 4 Performance Index Requirements..... | 19 |
| 5 System Structure Views..... | 21 |
| 5.1 External View of Air Cooling Cabinet System (with Dry Cooler) | 21 |
| 5.2 Internal View of Air Cooling Cabinet System..... | 22 |
| 6 Installation of Air Cooling Cabinet System | 23 |
| 6.1 Preparation Before Installation | 23 |
| 6.2 Equipment Handling, Unpacking, and Inspection | 25 |
| 6.3 Installation Flowchart | 26 |
| 6.4 Installation Height Difference and Distance Requirements..... | 27 |
| 6.5 Installation Material Requirements | 29 |
| 6.6 Internal System Installation | 29 |
| 6.7 Nitrogen Discharge | 30 |
| 6.8 Outdoor Unit Installation | 30 |
| 6.9 Indoor-Outdoor Unit Connection..... | 32 |
| 6.10 Nitrogen Charging & Pressure Retention | 35 |
| 6.11 Electrical Installation | 35 |
| 7 Use and Operation | 38 |
| 7.1 Safety Rules..... | 38 |
| 7.2 Commissioning Tools | 39 |
| 7.3 Comprehensive Inspection..... | 40 |
| 7.4 Unit Commissioning (Evacuation, Refrigerant Charging, etc.)..... | 41 |
| 7.5 Pre-Energization Check | 42 |
| 7.6 Unit Commissioning and Initial Startup | 43 |

| | |
|--|----|
| 7.7 Main Window | 43 |
| 7.8 Operating Modes | 44 |
| 7.9 Host Computer Communication Status..... | 44 |
| 7.10 Login Button | 44 |
| 7.11 Parameter Settings..... | 45 |
| 7.12 Information Query..... | 54 |
| 7.13 Analog Inputs | 55 |
| 7.14 Alarm Menu | 55 |
| 7.15 Software Version Information & System Time Setting..... | 57 |
| 7.16 MODBUS RTU Communication Protocol Implementation..... | 58 |
| 8 Common Faults & Troubleshooting Methods | 64 |
| 8.1 Fault Diagnosis and Handling of Each Component..... | 65 |
| 9 System Maintenance..... | 68 |
| 9.1 Overview | 68 |
| 9.2 Preventive Maintenance | 68 |
| 9.3 Electrical Maintenance..... | 69 |
| 9.4 Control Maintenance..... | 70 |
| 9.5 Fan Assembly..... | 71 |
| 9.6 Filter Maintenance | 71 |
| 9.7 Refrigeration System..... | 71 |
| 10 Safety Instructions | 74 |
| 10.1 Maintenance | 74 |
| 10.2 Operation | 75 |
| 10.3 Attention..... | 76 |

Revision History

| Version | Change Description | Previous Content | Revised Content | Change Date | Changed By |
|---------|--------------------|------------------|-----------------|-------------|------------|
| v1.0 | | | | | |

Copyright© Beijing Bitmain Technologies Ltd. All rights reserved.

- The content of this document may not be disseminated, reproduced, or forwarded to any third party without the authorization of Beijing Bitmain Technologies Ltd. (hereinafter referred to as "Bitmain"), nor may it be uploaded to public networks or other third-party platforms.

Trademarks

- BIMAIN, DCRACK, and other trademarks used in this document are the property of Beijing Bitmain Technologies Ltd.
- All other trademarks or registered trademarks mentioned in this document belong to their respective owners.

Software License

- Any commercial use of part or all of the data from the firmware or software developed by our company is strictly prohibited.
- Reverse engineering, decryption, or any other actions that undermine the original program design of the software developed by our company are prohibited.

Official website of Beijing Bitmain Technologies Ltd.: www.bitmain.com

Declaration

The purpose of the Product Use and Maintenance Manual (hereinafter referred to as the product manual) is only to provide guidance information to help you correctly use the DCRACK system (hereinafter referred to as this product). Before installing and using this product for the first time, you are obligated to carefully read all the materials delivered, especially the precautions mentioned in the product manual, which will help you better and safely use this product. Please keep the product manual properly for future reference.

Before using this product, please check if the product components are complete. If there are any missing parts, please contact BITMAIN in a timely manner and carefully inspect the product before installation and use.

When the following situations cause property damage to you or third-party personnel, BITMAIN will not be responsible, and the product damage caused is not covered by the warranty. If the user requests repair services, after being determined by the BITMAIN service organization, paid repair services can be provided.

- a. The entire equipment and components of this product have exceeded the free warranty period, or have been damaged due to abnormal use or natural environment.
- b. Incorrect or failure to install, use, and store this product according to the instructions and requirements of the product manual.
- c. Operate this product under operating environmental conditions that exceed the requirements specified in the product manual.
- d. Exceeding the installation and use scope specified in international standards or local laws, regulations, and industry regulations.
- e. Repairs or changes to this product by non BITMAIN authorized technical personnel;
- f. Use the software provided with the product outside of this product, or use other software other than non random software or specialized software on this product.
- g. Other scenarios that do not require liability within the legal scope of the country (region) where the operation is carried out.

Special attention: If the user purchases this product from a non BITMAIN official sales channel, BITMAIN does not guarantee that the product manual can be fully transmitted. Training and services

related to installation, use, maintenance, etc., should be provided by the seller. When using this product, it is assumed that the user is aware of the relevant installation, use, and maintenance content of the product, which also applies to the content of this declaration.

The product manual is not intended to indicate that BITMAIN has made any promises or warranties regarding its products and services, whether express or implied, including but not limited to the warranties of suitability, safety, and suitability for a specific purpose recommended in the product manual.

The photos, graphics, charts, and illustrations provided in the product manual are for explanatory and explanatory purposes only, and may differ from the actual product. The actual specifications and configurations of the product may change from time to time as needed, so they may differ from the content of the product manual. Please refer to the actual product purchased.

Due to the continuous iteration of products and the application of new designs, materials, and technologies, BITMAIN will make improvements or modifications to the software and hardware described in the product manual and the content of the product manual at any time based on factors including but not limited to product characteristics, product performance, and usage environment, without prior notice. If you find any inconsistencies between the actual situation of this product and the product manual during use, or if you want the latest information or have any questions or ideas, please feel free to call us or log in to the service website for inquiries.

1 About This Document

This manual mainly introduces the working principle, performance specifications, system operations, fault handling, and maintenance methods of the DCRACK system.

1.1 Application Scope

This manual is applicable to the DCRACK V1 model.

The following is a brief description of the installation and operation of this product, using the version for use with dry cooling towers as an example, unless otherwise specified.

1.2 Product Introduction

DCRACK is an intelligent cabinet system specifically designed for air cooling servers. It consists of a cabinet side and an external cooling system, enabling standalone operation and rapid deployment. Through the collaborative operation of compressors, fluorine pumps, dry coolers, and water curtains, it provides a constant 25°C environment for traditional air cooling servers while significantly reducing energy consumption (PUE=1.17 at 25°C ambient temperature). This achieves a dual breakthrough in efficient heat dissipation and energy economy.

1.3 Intended Audience

This manual is applicable to professional technical personnel who need to install, operate, and maintain the product. Professional technical personnel must meet the following requirements:

- a. Possess certain professional knowledge in electronics, electrical wiring, and machinery, and be familiar with electrical and mechanical schematic diagrams.
- b. Familiar with the composition and working principles of liquid cooling systems and related products.
- c. Should have received professional training related to the installation and trial operation of electrical products.
- d. Should have the ability to respond urgently to hazards or unexpected situations that occur during installation or trial operation.
- e. Familiar with the relevant standards and specifications of the country/region where the project is located.

1.4 Use of Manual

Please read the manual carefully before using the product.

The content of the manual will continue to be updated and corrected, but it is inevitable that there may be slight discrepancies or errors with the actual product. Users should refer to the actual product they purchased and can download or obtain the latest version of the manual materials through www.bitmain.com or sales channels.

1.5 Symbol Conventions

In order to ensure the personal and property safety of users when using the product, and to use the product more efficiently and optimally, the manual provides relevant information and highlights it with the following symbols.

The following are the symbols that may be used in this manual. Please read carefully to better use this manual.

Danger

Indicates a high potential danger that, if not avoided, could result in serious accidents such as personal injury, equipment damage, etc.

Warning

Indicates a moderate potential hazard, which, if not avoided, could result in serious accidents such as equipment damage.

Caution

Indicates a potential danger that, if not avoided, may result in the equipment not functioning properly.

2 Safety Description

2.1 General Safety Instructions

DISCLAIMER: The equipment company is not responsible for any of the following situations.

- a. Operation beyond the conditions specified in this document.
- b. Usage under installation and operating environments which are not specified in related international specifications (IEC, UL).
- c. Failure to follow the operation instructions and safety precautions on the product and in the document.
- d. Damage caused by abnormal natural environments.

2.2 All Safety Instructions

To ensure safety of humans and the equipment, pay attention to the safety symbols on the equipment and all the safety instructions in this document.

The "CAUTION", "WARNING" and "DANGER" marks in this document do not represent all the safety instructions. They are only supplements to the safety instructions.

1) Local Safety Regulations

When operating the equipment, you must follow the local laws and regulations. The safety instructions in this document are only supplements to the local laws and regulations.

2) Personal Requirements

- a. Only trained and qualified personnel are allowed to install, operate, and maintain BITMAIN equipment, and they must understand basic safety precautions to avoid hazards.
- b. Only trained and qualified personnel are allowed to install, operate, and maintain BITMAIN equipment.
- c. Only personnel certified or authorized by equipment provider are allowed to replace or change the equipment or components (including software).
- d. Any fault or error that might cause safety problems must be reported immediately to a supervisor.

3) Grounding Requirements

Equipment to be grounded must meet the following requirements:

- a. When installing the device, always make the ground connection first and disconnect it at the

end.

- b. Do not damage the ground conductor.
- c. Do not operate the equipment in the absence of a properly installed ground conductor.
- d. Ensure that the equipment is connected permanently to the protective ground.

4) Personal Safety

- a. Personnel other than the operator are now allowed near the equipment.
- b. Before operating a device, wear insulated shoes and insulated gloves, and pay attention to eye protection. Remove conductive objects such as jewelry and watches to avoid electric shocks or burns.
- c. Ensure that tool handles are insulated.
- d. Strictly avoid prolonged contact of dielectric cooling liquid with skin or sensitive areas of the body, such as the mouth, nose, eyes, and ears.

5) Equipment Safety

- a. Secure the keys and tools of the device during installation, operation, and maintenance.
- b. Before operate, ensure that the equipment is firmly secured to the floor or other solid objects, such as a wall or an installation rack.
- c. Do not block the ventilation while the product is operating.
- d. Tighten the screws by using a tool after initial installation and subsequent access to the panel.
- e. After the installation, remove packing materials from the equipment area.
- f. DO NOT put other solid and liquid impurities, such as metal, water, etc., to the dielectric coolant.
- g. No fireworks are allowed inside the container.
- h. When the dielectric coolant is replenished, smoke and fire are strictly prohibited around the liquid.
- i. In rainy and snowy weather, avoid opening the container door and maintenance window for operation to prevent rain and snow from splashing into the oil tank.

2.3 Electrical Safety

1) High Voltage

Danger

The high-voltage power supply provides power for the operation of the equipment. Direct contact or indirect contact with the high-voltage power supply through wet objects (or conductors) is fatal. Irregular and incorrect high-voltage operation may cause accidents such as fire or electric shock. Signal wires should be tied separately from high-current wires or high-voltage wires.

2) Leakage Current

Danger

1. Before turning on the power, all components of the equipment and the general grounding wire must be grounded, otherwise personal and equipment safety will be endangered.
2. If a "Leakage Current" sign is pasted near the power terminal of the equipment, the protective grounding terminal of the equipment chassis must be grounded before connecting to the AC input power supply to prevent the equipment's leakage current from causing electric shock to the human body.
3. Exposed cables in the equipment should be insulated immediately.

3) Power Cable

Danger

It is prohibited to install or remove the power cord while the power is on. The moment the power cord core comes into contact with a conductor, arcs or sparks will occur.

- a. Before installing or removing a power cable, turn off the power switch.
- b. Before connecting a power cable, check that the label on the power cable is correct.
- c. DO NOT use a power supply that is above or below the rated voltage range.
- d. If the power cable is damaged, it must be replaced by the manufacturer, its service agent or similarly qualified persons in order to avoid a hazard.
- e. The appliance should fit with means for disconnection from the supply mains having a contact separation in all poles that provide full disconnection under overvoltage conditions, and these means must be incorporated in the fixed wiring in accordance with the wiring rules.

2.4 Mechanical Safety

1) Drilling Holes

Warning

It is prohibited to drill holes in the cabinet by yourself. Drilling holes that do not meet the requirements will damage the internal components or pipelines of the equipment and damage the internal cables.

2) Fan

- a. When replacing a component, place the component, screws, and tools in a safe place. Otherwise, if any of them fall into the operating fans, the fans may be damaged.
- b. When replacing a component near fans, do not insert your fingers or boards into the operating fans until the fans are switched off and stop running.

3) Moving Heavy Object

Warning

1. Please wear protective gloves when carrying heavy objects to avoid scratching your hands.
2. When carrying heavy objects, be prepared to bear the weight to avoid being crushed or sprained by heavy objects.
3. When pulling the equipment out of the cabinet, be careful because the equipment installed on the cabinet may be unstable or heavy to avoid being crushed or hit.
4. It is prohibited for one person to carry heavy equipment alone. When transporting the device, do not tilt the device more than 15° (relative to vertical).
5. When moving or lifting the equipment, please protect the equipment to avoid scratches or bumps.
6. When transporting, it is strictly prohibited to use the components as a supporting point to prevent damage to the components.

2.5 Operation Safety

1) High Speed Running

Pay attention to the high-speed running part: fan.

2.6 Others

1) Binding Signal Cables

Caution

Bundling signal wires should be bundled separately from high-current wires or high-voltage wires.

2) Laying Out Power Cables

In extremely low temperatures, severe strikes or vibrations may damage the power cable

sheathing. To ensure safety, comply with the following requirements:

- a. Power cables can be laid or installed only when the temperature is higher than 0°C.
- b. Before laying out power cables which have been stored in a temperature lower than 0°C, move the power cables to an environment of the ambient temperature and store them at the ambient temperature for at least 24 hours.
- c. Handle power cables with caution, especially at a low temperature. Do not drop the power cables directly from the vehicle.

3) Storage

- a. Do not store devices near a heat source or under direct sunshine.
- b. Keep devices away from fire or high-temperature objects, especially devices injected with pressurized nitrogen or refrigerant; otherwise, explosion or refrigerant leakage may occur, causing personal injury.

4) Recovery and Disposal

The sign indicates that the product cannot be disposed of with other wastes that have a shell in European Union (EU) areas. To prevent possible environmental or human health harm from uncontrolled waste disposal, recycle it responsibly to promote the sustainable reuse of material resources.



Figure 2.1 Recycle marking.

5) Disposal of Waste Liquids

Discarded or spilled dielectric coolant should be collected and sent to the relevant departments for treatment, please do not pour into sewers, lakes, streams, groundwater and other natural water bodies to avoid pollution of the environment.

- a. In the event of a large spill, immediately disconnect the power supply and isolate combustible materials. After risk assessment, if necessary, organise the evacuation of people in the contaminated area to a safe area and inform the relevant departments of the situation. Wear personal protective equipment when cleaning up spills. During the emergency rescue, care should be taken to prevent personal injury and secondary disasters such as environmental pollution. It may be necessary to build a dam or dig a pit to contain the spill

and use a pump to transfer it to an airtight container for centralised treatment.

- b. For small spills, collect the spill, where possible, in closed containers with sand, activated carbon or other inert materials to absorb the residual liquid, and send to the appropriate departments for treatment. It can also be brushed with a non-flammable dispersant emulsion and the wash liquid disposed of safely.

3 System Composition and System Operation Principles

3.1 System Overview

The air cooling cabinet system provides cooling through an air cooling fluorine pump compressor system, integrated with forced air cooling (via dry cooling towers) and utilizing R410a refrigerant internally. This system is designed for environmental control in equipment rooms or computer data centers. It aims to ensure a reliable and secure operating environment for precision equipment such as sensitive electronic devices, industrial process equipment, telecommunication systems, and computing hardware.

3.2 System Composition

Table 3.1 Main components of air cooling cabinet

| Subcomponent | Function | Main components |
|-----------------------------------|--|---|
| Cabinet | Store air-cooling server | L-shaped rails and blanking panels |
| PDU | Controls all power outlets of individual cabinets and provides PDU data including total power, voltage, and current. | AC contactors, circuit breakers, power meters, and related accessories. |
| Precision Air Conditioning System | Delivers a constant-temperature environment with dynamic airflow circulation. | Compressors, Evaporator Coils, Electronic Expansion Valves (EEVs), EC Fans, Sight Glasses, Power Distribution Cabinets, Sensors |
| Pipelines | Deliver of liquid flow | Copper Refrigerant Piping, Condensate Drain Pipes, and related accessories |
| Dry Cooling Tower | The heat load is dissipated into the ambient atmosphere | Fans, Condenser Coils, Precision Sensors, and associated accessories |
| Spare Parts | Components, consumables, and spare parts required for air cooling system operation | Cabinet Screws, Cage Nuts, Cabinet Keys, Flexible Conduits, and related installation accessories |

3.3 System Operation Principles

The air cooling cabinet system consists of core components such as the compressor, condenser, expansion valve, and evaporator. Within this system: the compressor increases refrigerant pressure through compression, the condenser dissipates heat from the high-temperature, high-pressure refrigerant to the outdoors, the expansion valve (throttle valve) regulates refrigerant flow and pressure, the evaporator absorbs heat to achieve cooling. Through the coordinated action of these components, the entire system achieves air conditioning effects (functioning similarly to fluorine pump systems). The following is a detailed description of the working principle of this product:

1) Refrigeration Process

Cooling is achieved through the circulation of refrigerant.

First, the compressor draws in low-temperature, low-pressure refrigerant and mechanically compresses it, raising its temperature and pressure. The resulting high-temperature, high-pressure refrigerant then enters the condenser. Inside the condenser, it flows while exchanging heat with outdoor air. During this process, the refrigerant releases heat through radiation and convection, maintaining its gaseous state at elevated temperatures.

Next, the high-pressure refrigerant passes through the expansion valve. Restricted by the valve, its pressure and temperature drop abruptly. The refrigerant then enters the evaporator, where it forms a low-temperature, low-pressure vapor. Within the evaporator, the refrigerant absorbs heat from the equipment room, thereby reducing the ambient temperature inside the room.

2) Temperature Control

To ensure stable system operation, the air cooling cabinet system is equipped with temperature sensors, pressure sensors, and control devices that continuously monitor the temperature of both the refrigerant and the air inside the cabinet. Based on temperature fluctuations, the control system enables manual or automated adjustment of refrigerant flow rate and fan speed to maintain equipment within the optimal operating temperature range.

3) Safety Monitoring and Protection

The product provides customized anti-leakage and alert functions and other parameter monitoring functions as safety protection to prevent accidents such as system overheating or coolant leakage:

Multiple leakage detection mechanism: Pressure sensors detect refrigerant line pressure to promptly identify and address leaks. This product currently incorporates multiple leakage monitoring and alert mechanisms.

Emergency shutdown: In the event of serious system failure, an emergency stop device on the front panel of the air conditioning unit immediately de-energizes the control circuitry to protect both equipment and personnel safety.

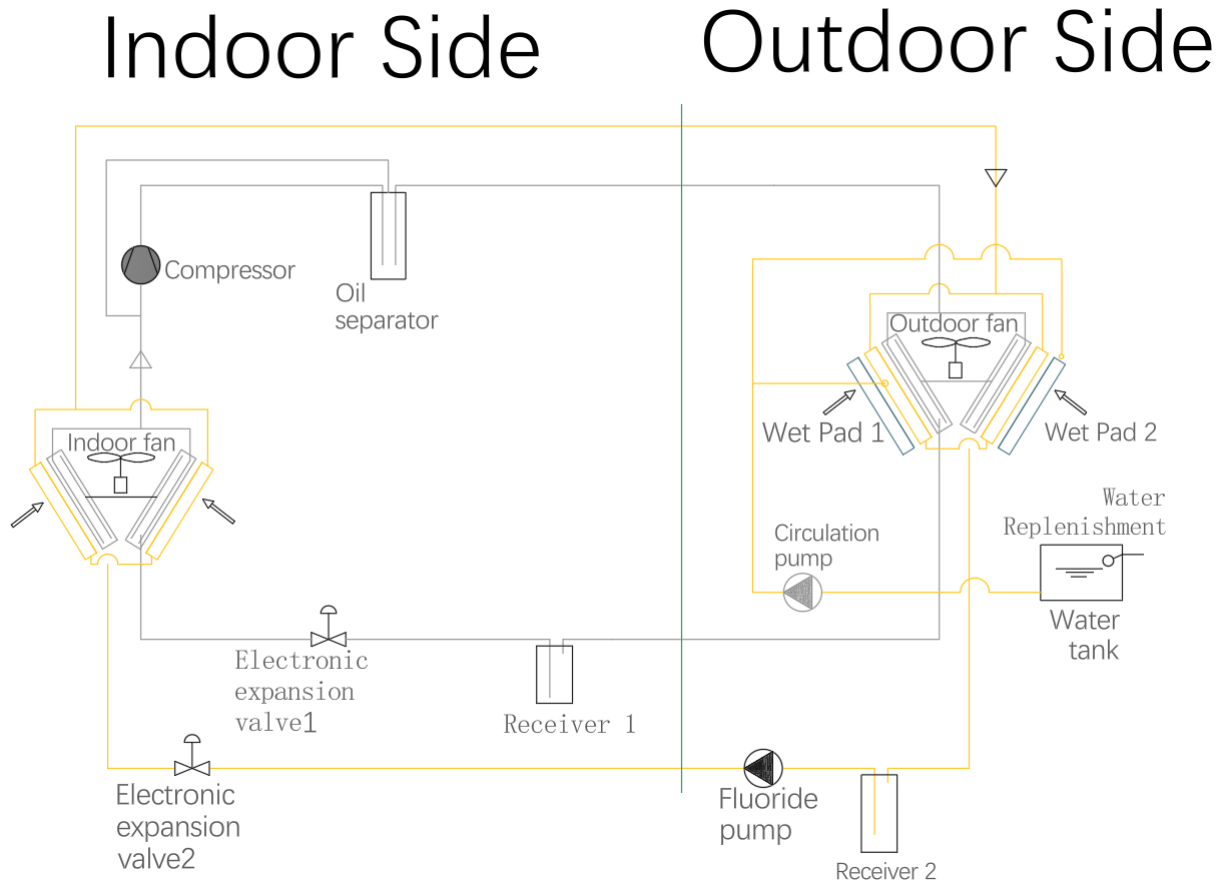

Figure 3.1 Diagram of DCRACK V1 Air Cooling Cabinet System and Dry Cooler Principle

4 Performance Index Requirements

Table 4.1 Air Cooling Cabinet System Performance Index Requirements

| SN | Items | Performance Index | Remarks |
|----------------------|-------------------------------------|------------------------------------|--------------------------------------|
| Environment | | | |
| 1 | Working Temperature | -20~45°C | Outdoor Ambient Temperature |
| | Working Temperature | 5 ~ 45°C | Indoor |
| 2 | Working Humidity | 20 ~ 80% | |
| 3 | Storage Temperature | -35 ~ 70°C | |
| 4 | Storage Humidity | 5 ~ 95% | Zero Condensation |
| 5 | Altitude | ≤ 1000 m | |
| Indoor System | | | |
| 1 | External Dimensions (L×W×H) (mm) | 1600 × 1200 × 2350 | |
| 2 | Input Voltage and Frequency | 380±5% V, 50 Hz, 3P/N/PE | |
| 3 | Transport Weight (kg) | 668 | Excluding servers and coolant |
| 4 | Operating Weight (kg) | 686 | Including coolant, excluding servers |
| 5 | Rack Position | 47U | |
| 6 | Maximum Load Capacity(kW) | 36 | |
| 7 | Supply Air Temperature | 25°C | Standard Operating Conditions |
| 8 | Return Air Temperature | 38°C | Standard Operating Conditions |
| 9 | Internal Recirculation Fan Quantity | 3 | |
| 10 | Single-Fan Power (kW) | 0.48 | |
| 11 | PUE@25°C | 1.17 | |
| 12 | PDU Plug | 6*1P/20A Hydraulic Circuit Breaker | Single Phase-12pcs |

| SN | Items | Performance index | Remarks |
|--------------------------|---|--------------------------|-------------------------------------|
| Dry Cooling Tower | | | |
| 1 | Type | Dry cooling tower | |
| 2 | External Dimensions (L×W×H) (mm) | 1896×1026×2180 | |
| 3 | Heat Dissipation Capacity (kW) | 36 | |
| 4 | Fan Quantity | 2 | |
| 5 | Fan Speed (each) | 1200RPM | |
| 6 | Fan Airflow (each) | 12940m ³ /h | |
| 7 | Rated Power (kW) | <10 | |
| 8 | Transport Weight (kg) | 396 | Excluding coolant and server |
| 9 | Operating Weight (kg) | 414 | Including coolant, excluding server |
| 10 | Inner Diameter of Inlet and Outlet Pipes | φ22/φ16 | |
| 11 | Noise @ 25°C, 10 m | 74 dBA | |
| 12 | Pipe Material | TP2M (Copper) | |

5 System Structure Views

5.1 External View of Air Cooling Cabinet System (with Dry Cooler)

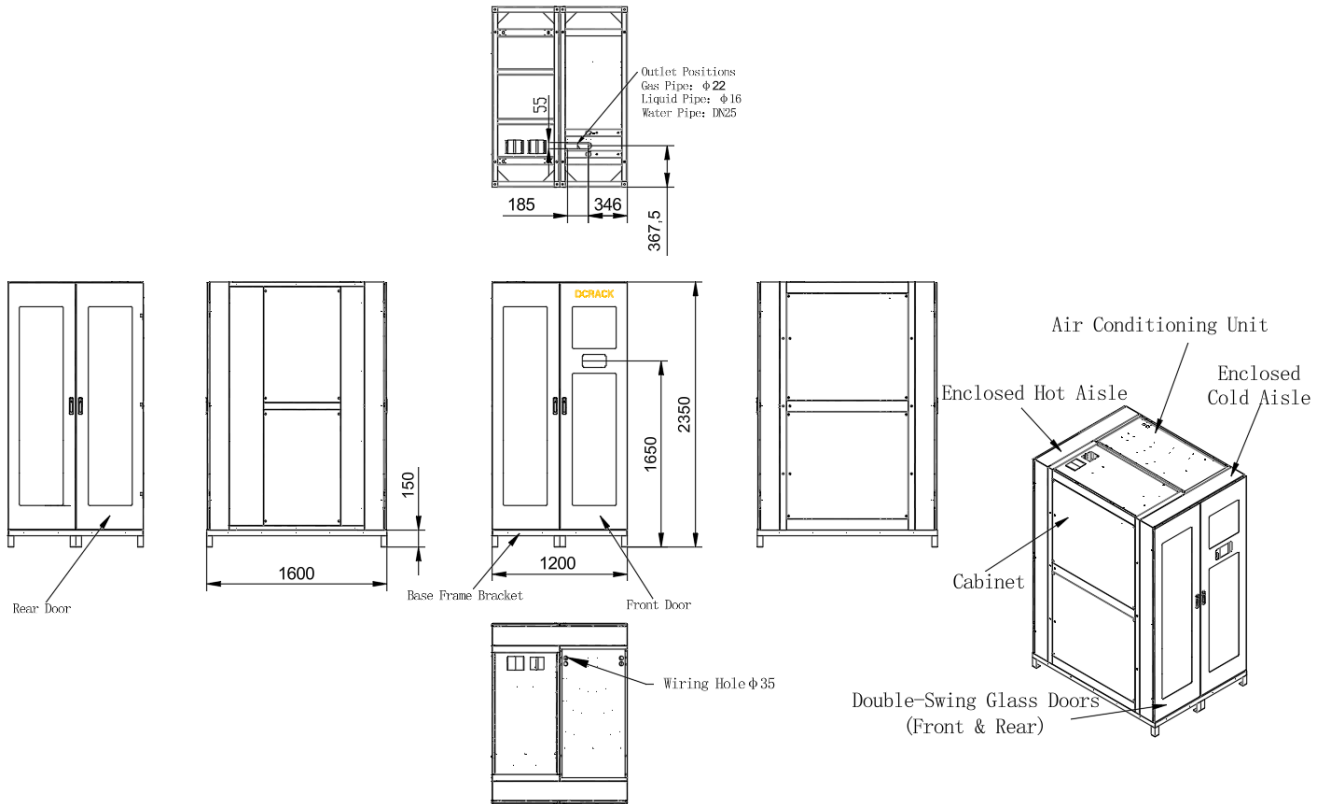

Figure 5.1 External View of Air Cooling Cabinet System

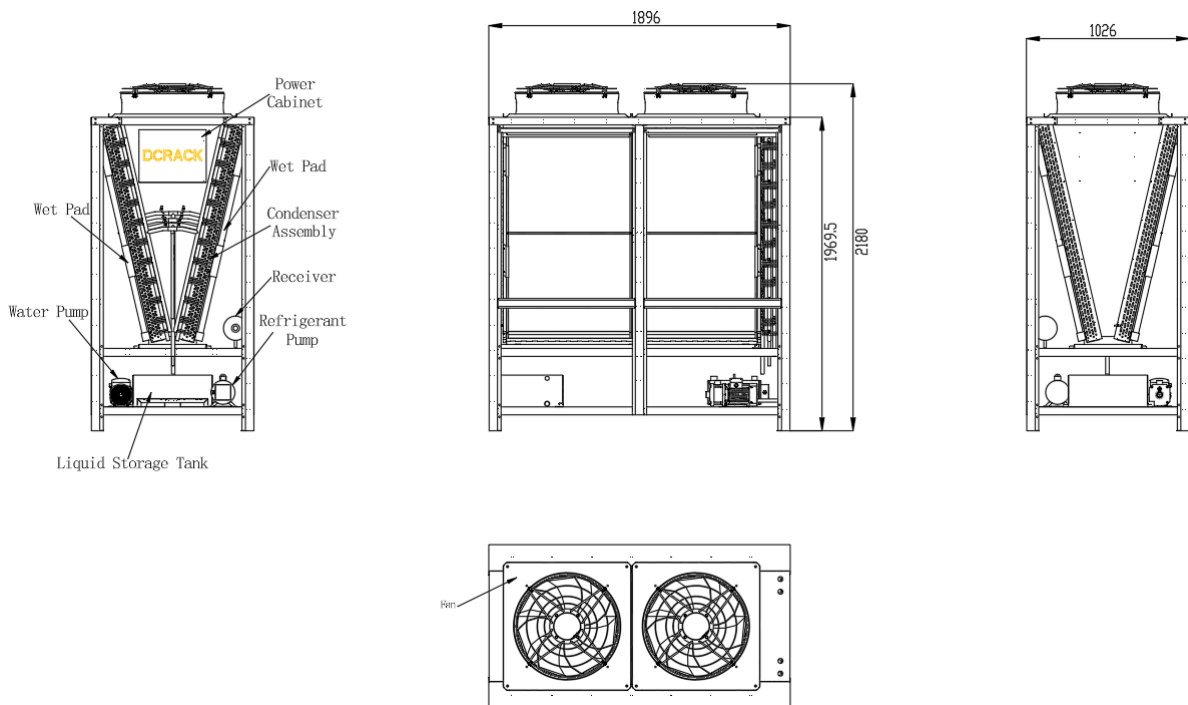

Figure 5.2 Dry Cooler

5.2 Internal View of Air Cooling Cabinet System

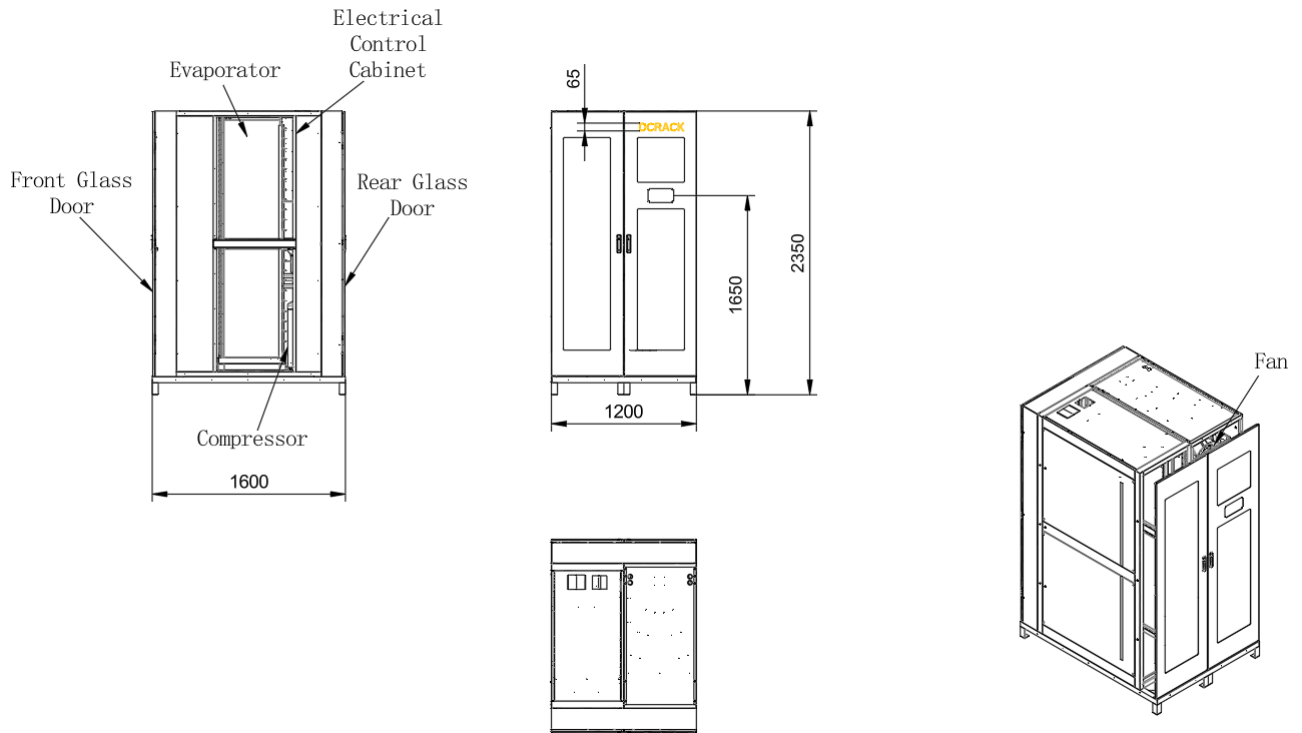

Figure 5.3 Internal View of Air Cooling Cabinet System

6 Installation of Air Cooling Cabinet System

6.1 Preparation before Installation









- a. Installation Requirements
 - This product must meet the ground load bearing, electric power, and space requirements on both sides before installation.
 - The site needs to support a total of about 3 tons of weight (including air cooling server).
 - Reserve space on both sides for the operator to pass through, recommended spacing: 3 meters between the sides of the two containers and 6 meters front to back.
- b. Transportation Requirements
 - A 3-ton forklift needs to be prepared for loading and unloading the air cooling cabinets and the dry coolers.

Caution

Do not install electrical equipment or distribution devices during thunderstorms.

- c. Prepare labor protection supplies
 - Installation personnel must be equipped with personal labor protection supplies such as safety helmets, safety harnesses, safety shoes, and gloves.
- d. Prepare installation tools

Table 6.1 General Tools

| Tool Appearance, Specifications and Nomenclature | | | |
|---|---|--|---|
| Adjustable Wrench | Phillips Screwdriver (M4/M6/M8) | Flathead Screwdriver (M3/M4) | Socket Wrench (18mm) |
|  |  |  |  |
| Torque Wrench (28mm) | Open-end Wrench (18mm/13mm) | Box-end Wrench | Diagonal Cutting Pliers |
|  |  |  |  |
| Combination Pliers | Long-nose Pliers | Insulation Sealant Tape | Combination Square |







| | | | |
|---|---|--|---|
|  |  |  |  |
| A-frame Ladder(2m) | Flashlight | Tape Measure | Hammer Drill |
|  |  |  |  |

Table 6.2 Transport and Packaging Removal Tools



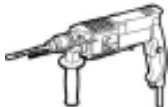

| Tool Appearance, Specifications and Nomenclature | | | |
|--|--|---|--|
| Manual Pallet Jack | Electric Forklift | Lifting Sling (SWL \geq 400kg) | Lever Hoist (Capacity \geq 400kg) |
|  |  |  |  |

Table 6.3 Pipeline Installation Tools





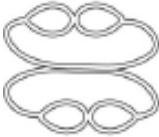







| Tool Appearance, Specifications and Nomenclature | | | |
|---|---|--|---|
| Cutter | Thread Sealant/Tape | Welding Torch | Copper Brazing Rod |
|  |  |  |  |
| Oxygen | Acetylene | Nitrogen | |
|  |  |  | |

Table 6.4 Electrical Installation Tools

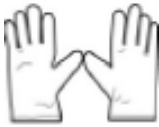
| Tool Appearance, Specifications and Nomenclature | | | |
|--|-------------------|---------------|-----------------|
| ESD Gloves | Insulating Gloves | Wire Stripper | Electrical Tape |

| | | | |
|---|---|--|---|
|  |  |  |  |
| Heat Gun | Wire Crimping Tool | | |
|  |  | | |

6.2 Equipment Handling, Unpacking, and Inspection

1) Transportation and Handling

During transportation, it is preferable to choose rail or maritime transport. When selecting road transport, opt for highways in good condition to prevent excessive jolting. The air-cooled cabinet system is relatively heavy; refer to the weight parameters on the packaging box. For unloading and handling, use mechanical tools such as electric forklifts to move the equipment as close to the installation site as possible. When unloading and transporting with a forklift, insert the forks in the direction shown in the diagram, and aim to lift at the center of gravity to prevent tipping.



2) Storage Instructions

If the unit needs to be placed outdoors before installation in the machine room, care should be taken to protect it from debris, rain, snow, and damage from animals, as well as to avoid damaging the protective film on the unit's surface. In summer, do not expose the unit to direct sunlight, as this may cause deformation of the insulation board. If the unit is to be installed outdoors, please specify this when placing the order, and we will make special arrangements. The unit should be stacked according to the markings on the outer packaging.

3) Unpacking

Try to move the equipment to the location closest to its final installation site before unpacking.

Unpacking steps:

a) Remove the packaging materials. The unit is packaged with foam; sequentially remove the straps, stretch film, cardboard top cover, wooden cover, protective materials, and foam packaging (if any).

b) Remove the dry cooler packaging. Once the dry cooler is correctly positioned as required, remove the cushioning pad from the U-tube at the condenser end (if any).

Note: When manually moving the condenser, do not touch the copper pipes to avoid bending or deforming them, which may lead to leaks.

4) Air Pressure Inspection

Operation Steps

Step 1: Open the rear door.

Step 2: Rotate the filter mesh flap 90° to the right and remove the filter mesh.

Step 3: Remove the dryer bag.

Step 4: Check whether the valve caps in the system are missing.

a) If there are no valve caps, please contact the after-sales personnel for the project.

b) If there are valve caps, unscrew the cap and use it to press down on the valve core. If gas is released, it indicates normal operation; if no gas is released, please contact the after-sales personnel for the project.

6.3 Installation Flowchart

The installation process for the internal system is shown in Figure 6.1:

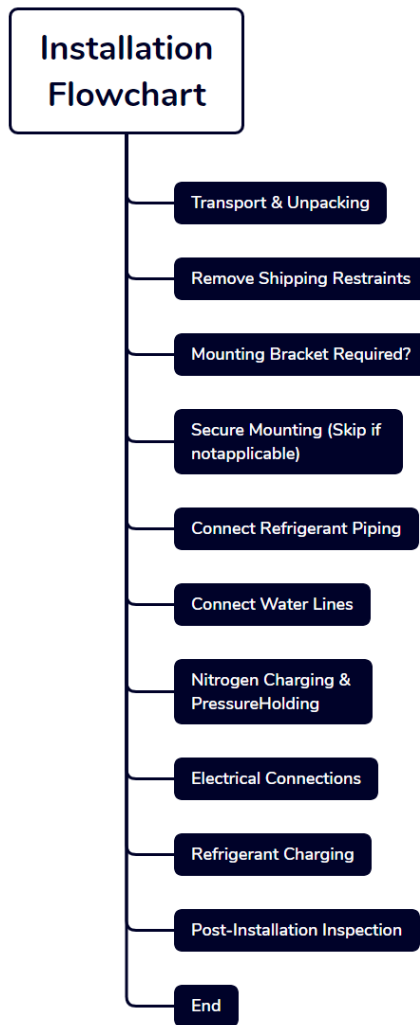

Figure 6.1 Installation Process for the Internal System

6.4 Installation Height Difference and Distance Requirements

1) Refrigerant Pipe Selection Considerations:

- a) Vibration loops must be installed at indoor unit refrigerant pipe connections;
- b) Minimize bends to ensure the shortest possible piping between indoor and outdoor units;
- c) After finalizing the optimal piping route, calculate all fittings (elbows, etc.) causing local pressure drop losses and convert them to equivalent straight pipe length;
- d) If single-line equivalent length exceeds 30m, add extension kits (installed directly at indoor units during setup);
- e) When outdoor units are positioned significantly higher than indoor units (>5m height difference), install oil traps at 5–7m vertical intervals;
- f) Pipe diameter impacts refrigeration system pressure drop and performance. Select diameters based on total piping length between units.

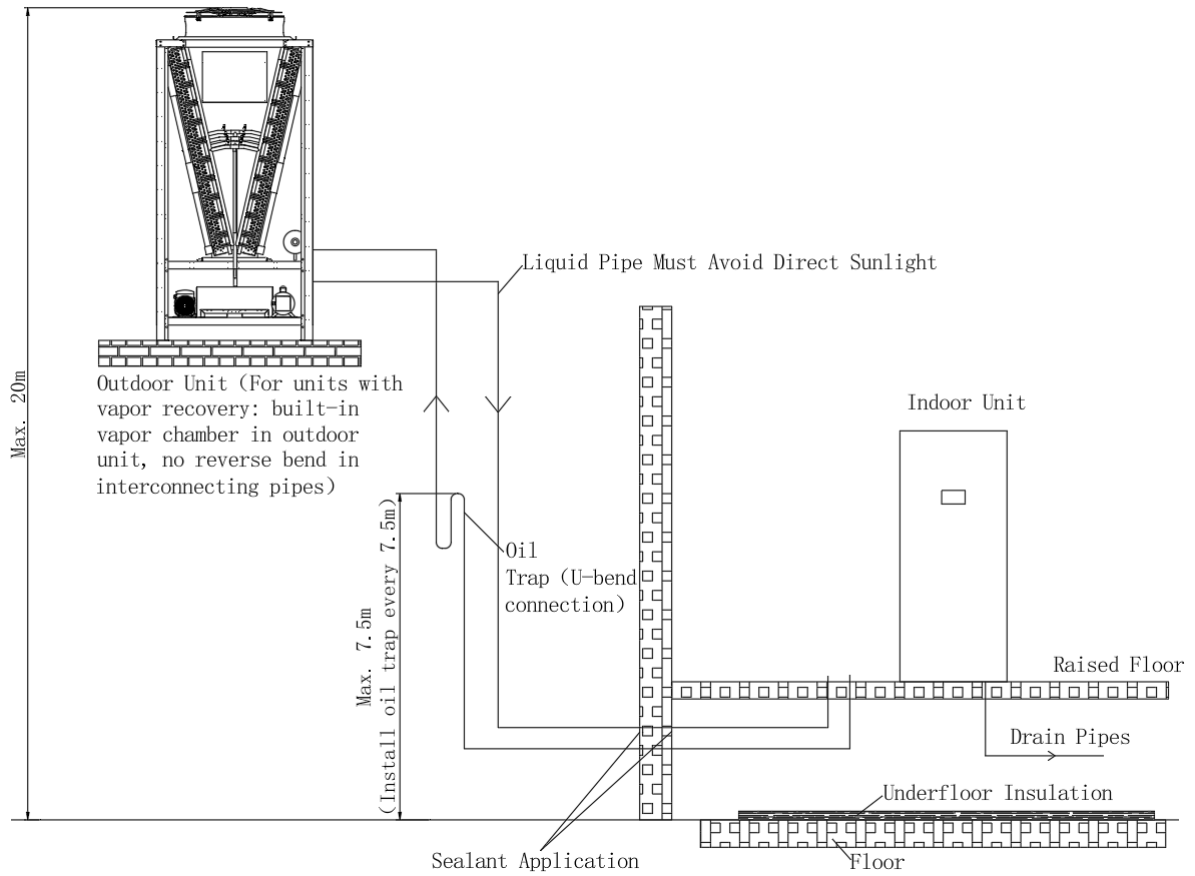

Figure 6.2 Installation Diagram for Outdoor Unit Mounted Higher than Indoor Unit

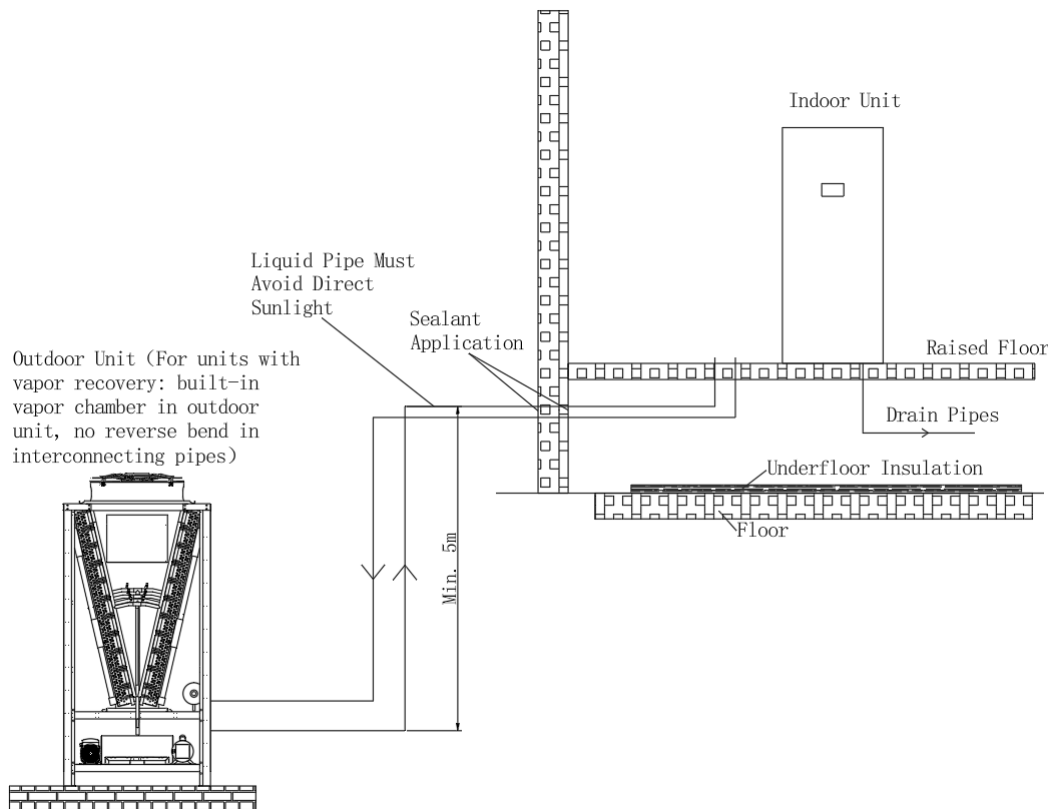

Figure 6.3 Installation Schematic for Elevated Indoor Unit

6.5 Installation Material Requirements

1) Copper Pipe Requirements

a) Refrigerant pipes shall use T2-grade hard copper tubes conforming to GB/T18033-2000 standard, annealed-treated; pipes must be straight with metallic luster, exhibiting copper-red color; free from oil contamination, blackening, severe oxidation, cracks, or defects.

b) Wall thickness at cut ends must be uniform; specific thickness requirements are detailed in the table below.

c) For 90-degree elbows and couplings used in copper pipe welding, inner surfaces of elbows must be smooth to minimize flow resistance, wall thickness specifications follow Table 6.5.

Table 6.5 Wall Thickness Specifications

| Copper Pipe Specifications (mm) | Wall Thickness δ (mm) | Elbow Specifications | Wall Thickness δ (mm) |
|---------------------------------|------------------------------|-------------------------|------------------------------|
| $\leq \phi 12.7$ | ≥ 0.9 | $\leq \phi 12.7$ | ≥ 1.0 |
| $\phi 12.7 - \phi 19.1$ | ≥ 1.0 | $\phi 12.7 - \phi 19.1$ | ≥ 1.2 |
| $> \phi 19.1$ | ≥ 1.2 | $> \phi 19.1$ | ≥ 1.5 |

2) Insulation Sleeve Requirements

a) Insulation sleeves must have clearly visible markings, excellent elasticity, and be free from defects such as air bubbles.

b) Exterior surfaces shall be smooth without scratches or cracks.

c) Nominal wall thickness: 9mm; Closed-cell foam materials with density $\geq 30\text{kg/m}^3$ are recommended for engineering applications.

6.6 Internal System Installation

Note: During electric welding operations, strictly prohibit using indoor units, outdoor units, or copper pipes as current return path conductors. This will cause fatal damage to equipment beyond repair.

1) Installation Requirements

a) In-row Installation

Row-based air conditioning units shall be positioned within the server rack array and installed in-line with the server cabinets. Adopting a horizontal airflow design—supplying cold air from the cold aisle and returning hot air through the hot aisle—effectively eliminates the risk of cold and hot air mixing. This ensures uniform temperature distribution across server cabinets, eliminates localized hot spots, enhances server operational reliability, and significantly reduces unnecessary energy consumption.

b) Clearance Provision

Adequate operational and maintenance space must be reserved both in front of and behind the row-based air conditioning units. It is recommended to maintain a clearance of at least 1.0 meter from the front and rear doors of the equipment, which should be kept free of obstructions. This maintenance space also facilitates unimpeded airflow, thereby improving heat exchange efficiency.

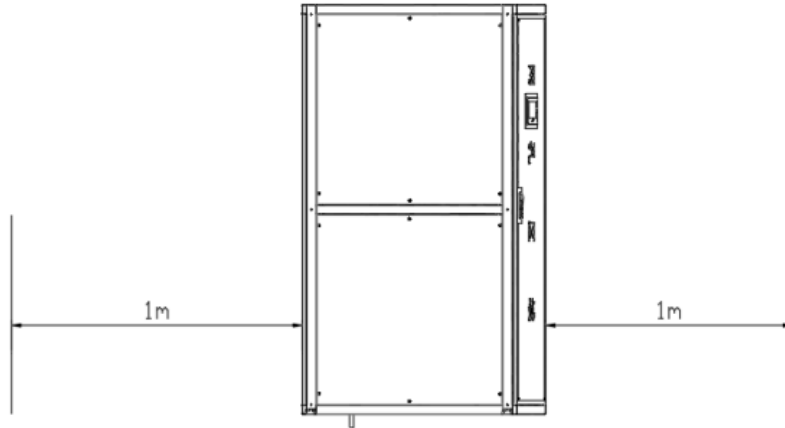

Figure 6.4 Maintain $\geq 1.0\text{m}$

6.7 Nitrogen Discharge

The unit is pre-charged with nitrogen for pressure maintenance before leaving the factory. To ensure safety, all nitrogen must be completely released from the air conditioning system to dissipate internal pressure before welding pipelines or repairing welded joints. Remove the schrader valves from the gas and liquid lines, then attach the gauge hose to the valves to discharge the nitrogen.

6.8 Outdoor Unit Installation

1) Determining Installation Location

The installation site must:

- a) Have no obstructions within 1200mm of the condenser outlet.
- b) Provide $\geq 300\text{mm}$ maintenance clearance on front/rear or left/right sides of the condenser.
- c) Use a concrete base (recommended: $350 \times 350\text{mm}$, height site-dependent) and No.8 channel steel.
- d) Position all system components on the same side for maintenance accessibility.
- e) Allow sufficient clearance between units if secondary relocation is required.

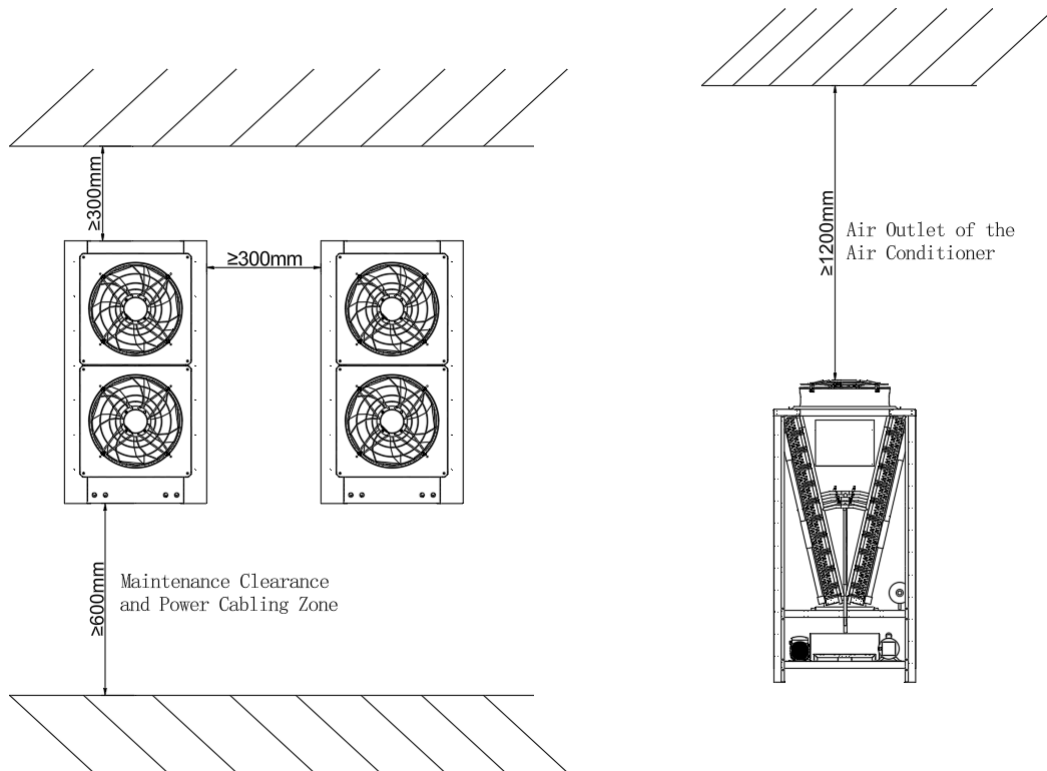

Figure 6.5 Outdoor Unit Installation Schematic

Anchor the unit base with expansion bolts, using $\geq 10\text{mm}$ anti-vibration rubber pads as shown:

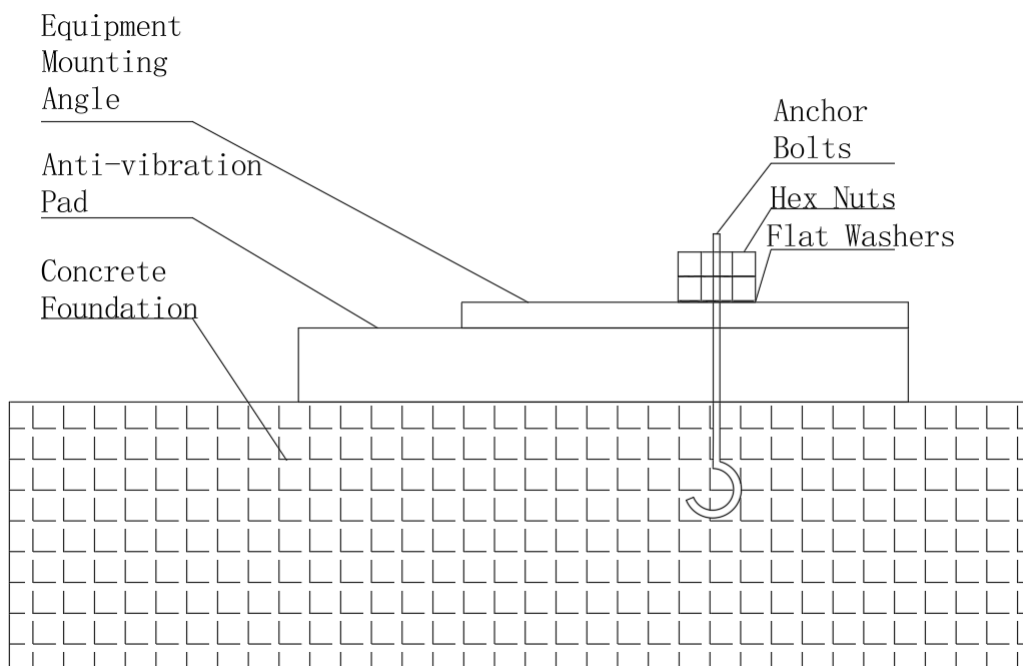

Figure 6.6 Base Reference Diagram

2) Installation Precautions

May be installed horizontally. Ensure: secure ground anchoring, prevention of rainwater ingress,

braze condenser-pipe connections (insertion depth \geq pipe diameter) to prevent gas leakage.

NOTES: For horizontal exhaust: Avoid orienting exhaust against prevailing monsoon winds.

NOTES: Roof installation without building lightning rod: Install 2m-high lightning rod exceeding unit height, weld rod to building's lightning protection belt.

6.9 Indoor-Outdoor Unit Connection

1) Bottom Piping Configuration (Indoor Unit)

Note:

- Insulate copper pipes. When penetrating walls/obstacles, isolate pipes using vibration pads to prevent direct contact. Seal pipes during >15 min welding intervals to exclude dust/moisture/particles.
- Use high-silver-content brazing alloy for joints with continuous nitrogen purging during welding.
- Minimize system exposure time (<15 min) post-welding to ensure reliability.

2) Piping Installation Procedure

Step 1: Slide insulated copper pipes (gas/liquid lines) from indoor to outdoor unit; secure properly.

Step 2: Remove service valve caps; flare pipe ends (see Fig.6.7 Flaring Requirements) ensuring smooth, concentric flares.

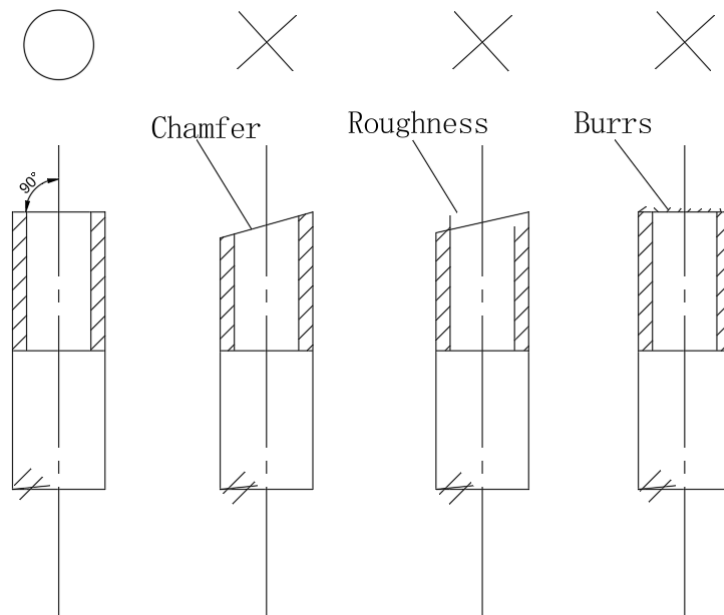

Figure 6.7 Flaring Requirements

Step 3: Align pipes vertically for brazing or tighten with wrenches (for units with shutoff valves).

Step 4: Route wiring along pipes, secure, then bundle with tape.

Step 5: Perform vacuum evacuation post-connection.



Technical Instructions

- Nitrogen Purge Requirement

Units are factory-charged with nitrogen for pressure retention. Before connecting indoor/outdoor piping, fully evacuate nitrogen from the system.

- Vacuum Evacuation Protocol

After interconnecting pipes: Evacuate lines to <500 microns vacuum; Isolate vacuum pump; verify zero pressure rise over 24h

- Refrigerant Charging

Post vacuum validation, charge additional refrigerant per piping length specifications.

- Oil Management

Install oil traps every 7.5m on vertical risers to ensure compressor oil return.

- Piping Extension

For insufficient lengths: Certified welders may extend pipes using appropriate brazing alloys.

Step 6: Insulate refrigerant lines entirely with foam sleeves.

Step 7: For runs >20m equivalent length: Consult manufacturer for extension kits.

3) Pipe Support & Specifications

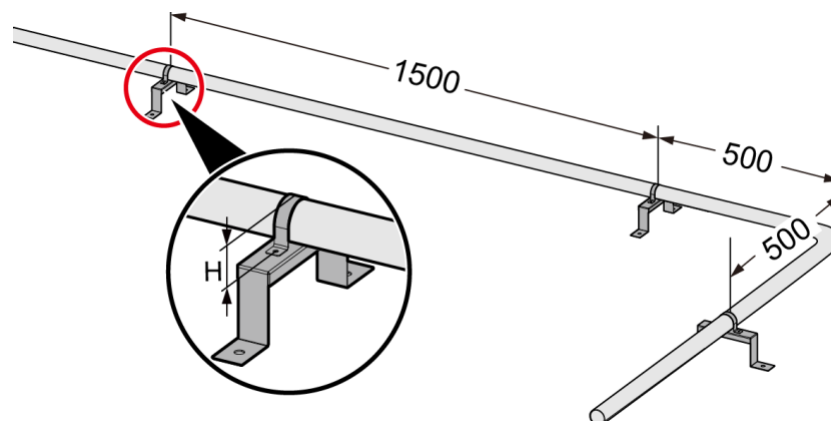

Figure 6.8 Pipe Support



Technical Instructions

The height H of the U-type pipe clamp = diameter of the insulated pipe - 5mm. Pipe supports need to be procured by engineering.

It is recommended to use 304 stainless steel for the pipe supports and clamps.

When the pipe is a straight section, a support should be added every 1500mm. When the direction of the pipe changes, a support should be added 500mm from the point of change.

The recommended pipe diameter for the main power cable and connecting copper pipe for indoor and outdoor units is as follows in Table 6.6.

Table 6.6 Recommended Pipe/Cable Sizing

| Circuit Breaker | Cable (mm ²) | <10m Run | | <20m Run | | <40m Run | |
|-----------------|--------------------------|--------------|--------------|--------------|--------------|--------------|--------------|
| | | Gas ø(mm) | Liq ø(mm) | Gas ø(mm) | Liq ø(mm) | Gas ø(mm) | Liq ø(mm) |
| 50A | 10 | 22 | 19 | 25 | 19 | 28 | 22 |

4) Refrigerant Piping Installation

a) For welded or flanged pipe connections, the welder must be certified, with the certification scope matching the welding requirements. All welding must be performed according to the specified welding procedure.

b) All refrigerant pipes must maintain clean inner copper surfaces. Strictly prevent moisture ingress during copper pipe welding. After welding, it is recommended to purge impurities and oxides using nitrogen. Vibration isolation supports (or appropriate measures) shall be applied to refrigerant pipelines to prevent vibration transmission to the building. Pressure drop losses and compressor oil return must be considered, avoiding oil accumulation in system components. Horizontal sections of the discharge pipe must slope downward at a minimum gradient of 1:200 (5 mm drop per meter) after leaving the compressor. All piping under raised floors must be arranged to prevent airflow obstruction anywhere in the computer room. Ensure pipes do not overlap, and seal wall penetrations to prevent cold air leakage. Sections of the discharge pipe passing through air-conditioned spaces should be insulated to minimize heat loss. To facilitate oil return to the compressor, install an oil trap every 7.5 m maximum in vertical refrigerant lines, following the upward flow direction of the refrigerant.

c) During piping installation, promptly remove contaminants such as dust, thread debris, and welding slag to minimize residual impurities within the pipes.

d) If the single-line equivalent length exceeds 30 m, or if the vertical height difference between indoor and outdoor units exceeds the values shown in Table 6.6, consult the manufacturer before installation to confirm whether additional piping extension components are required. Regardless of whether the length exceeds 30 m, a check valve must be installed at the condenser inlet to prevent liquid refrigerant from flowing back to the compressor during shutdown. **(When installing extension components, ensure the refrigerant flow direction aligns with the direction marked on the valve body.)**

Table 6.7 Vertical Height Difference Between Indoor and Outdoor Units

| Configuration | Value |
|---------------------------|-----------|
| Outdoor unit above indoor | Max: +20m |
| Outdoor unit below indoor | Min: -5m |

Table 6.8 lists the recommended pipe sizes as equivalent lengths, with the resistance losses from

elbows and valves already accounted for. The installer should verify on-site whether these are appropriate.

Table 6.8 Fitting Equivalent Length (m/per fitting)

| Pipe OD (in) | Equivalent Length(m) | | |
|--------------|----------------------|-----------|------|
| | 90° Elbow | 45° Elbow | Tee |
| 5/8 | 0.27 | 0.15 | 0.76 |
| 3/4 | 0.3 | 0.18 | 0.76 |
| 7/8 | 0.44 | 0.24 | 1.1 |
| 1-1/8 | 0.56 | 0.3 | 1.4 |

6.10 Nitrogen Charging & Pressure Retention

WARNINGS:

Ensure all indoor/outdoor unit piping welds are complete.

Do not remove hoses/gauges during pressure retention to prevent nitrogen leakage.

Verify schrader valve cores are intact before charging.

Use nitrogen ONLY for leak testing.

Connect gauge high-side to nitrogen cylinder fitted with pressure regulator; low-side to discharge line schrader valve.

Charge slowly to 3.5 MPa, hold for 24h. Pass criteria: ≤ 0.3 bar pressure drop.

After leak test, fully evacuate nitrogen per Chapter 6, Article 5.

6.11 Electrical Installation

1) Circuit Installation

a) Wiring must be performed by certified/licensed technicians.

b) Route power cables: Avoid foot/vehicle traffic areas; Use dedicated conduits; Install overhead cable trays across walkways/driveways; Secure cables with strain relief clamps.

c) Provide dedicated circuit per unit with disconnect switch and overload protection.

d) Implement waterproofing & rodent-proofing throughout cable runs.

e) Isolate low-voltage signal cables (e.g., comms) from power lines to prevent EMI.

2) Local/Remote Control

When the unit is controlled locally, it accepts the on/off and timing control from the display screen, while shielding the on/off control from remote DI points and the Modbus monitoring port.

When the unit is controlled remotely, it shields the on/off and timing control from the display screen and accepts the on/off control from remote DI points and the Modbus monitoring port.

Specifically, when the remote control point is closed, the system enters operation mode. If the remote control point changes from closed to open, the system stops. If the remote control point is open, it can accept on/off control from the Modbus monitoring port.

3) Key Specifications

a) The maximum allowable current values corresponding to the wire diameters of standard copper core cables.

Table 6.9 Cable Sizing

| | | | | | | |
|---------------------------------|-----|-----|-----|----|----|----|
| Cu Conductor (mm ²) | 1.0 | 1.5 | 2.5 | 4 | 6 | 10 |
| Max Current (A) | 6 | 10 | 16 | 25 | 32 | 50 |

c) Comm Cable Requirements

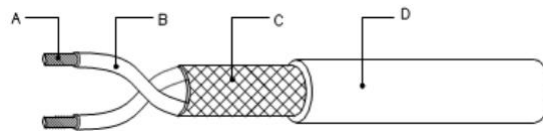

Figure 6.9 Shielded Twisted Pair Diagram

- A: Conductor (tinned copper, $\geq 0.5\text{mm}^2/20\text{AWG}$)
- B: Insulation
- C: Shield (tinned copper braid, $\geq 95\%$ coverage)
- D: PVC jacket

Note: Use cables meeting UL 2547/UL 2791 with tight shielding & small twist pitch.

Critical Notes:

- ① Comply with local/national electrical codes
- ② Cable sizing per unit nameplate FLA & local regulations
- ③ Power supply: $380\text{V} \pm 10\%$ 3N~ 50Hz
- ④ Installation by certified electricians only
- ⑤ Verify zero voltage & LOTO before connection

4) Indoor Unit Wiring

The unit has a designated user entry hole at the top, allowing users to choose the wiring method based on the site conditions.

Table 6.10 Indoor Unit Wiring

| Cable Type | Specs (mm ²) | Conductor | Qty | Remarks |
|--------------------|--------------------------|-----------|-----|------------------|
| Power Cable | 5*10 | YJV | 2 | Rubber-insulated |
| Interconnect Cable | 4*1 | YJV | 3 | Rubber-insulated |

| | | | | |
|------------|-----|------|---|----------|
| Comm Cable | c*1 | RVSP | 1 | Shielded |
|------------|-----|------|---|----------|

5) Communication Protocol

Standard: Modbus RTU via RS485

Parameters:

Communication method: Serial asynchronous half-duplex.

Baud rate: 9600bps

Data bits: 8

Start/Stop bits: 1/1

Parity: None

6) Outdoor Unit Wiring

a) Power source: Indoor unit E-box OR site distribution cabinet (indoor preferred).

Critical: Correct phase sequence (L1/Y-L2/G-L3/R), neutral, and PE grounding. No phase loss/reversal!

b) Comm wiring: Connect indoor-outdoor per terminal diagram.

7) Post-Installation Verification

Confirm:

- a) Supply voltage matches nameplate rating
- b) No open/short circuits in system
- c) Power/ground cables secured at breakers & units
- d) Correct fuse/breaker ratings
- e) Control cables properly terminated
- f) All terminals torqued to spec

7 Use and Operation

7.1 Safety Rules

1) Hazard Level

Danger

 Inside the device is a live label, and it is prohibited to open protective panels with live labels. Even in case of power outage, non professionals are prohibited from opening the cover plate.

2) Precautions for Use

- a. Equipment should avoid wiring midway and is strictly prohibited from being used in parallel with other equipment.
- b. If there are any abnormalities in the equipment, it should be shut down, disconnected from the power supply, and inspected.
- c. There are emergency stops on the left side of indoor HMI. When an emergency occurs, pressing the emergency stop will immediately disconnect the power switch.
- d. After an emergency reset, first turn the main switch to the **OFF** position and then power on again.
- e. Daily operation management of the unit shall be assigned to designated personnel. All operational procedures must comply with relevant regulations, including pre-startup inspections.

Warning

All emergency stop buttons used in this system are rotary release type. After the emergency stop button is pressed and confirmed and confirming that the system is functioning properly, it is necessary to rotate the emergency stop button counterclockwise to release it. Then, the main switch of the distribution cabinet and the main control cabinet can be closed. Before closing the switch, it needs to be turned to the OFF position and re-closed.



Figure 7.1 Emergency Stop

7.2 Commissioning Tools

Wrenches: Adjustable wrench

Evacuation & Charging Tools: Pressure gauge (Range ≥ 4.0 MPa), Hose (Pressure resistance ≥ 4.5 MPa), Vacuum pump

Measuring Instruments: Multimeter, Clamp meter, Electronic scale

Protective Equipment: Insulating gloves, Antifreeze gloves

Other: Flashlight

7.3 Comprehensive Inspection

Refer to the relevant sections of the "User Manual" to verify that the refrigerant piping system, input power, and water inlet/outlet pipes are installed correctly. Piping and wiring should be routed appropriately. Electrical circuits must be safe and correct. Mechanical connections should be secure and reliable.

Before proceeding with system commissioning, check and ensure the following:

- a) Remove the plastic film from the return air grille on the front door of the indoor unit and from other areas (indoor unit door panels and outdoor unit) before commissioning.
- b) Fans are installed correctly, fan guide ring cover plates are properly installed and not deformed, and there is no interference between the fans and the guide rings.
- c) The condensate drain line (the unit comes with a drain pipe) has been checked for leaks and ensures unobstructed water flow.
- d) The main power supply voltage and frequency are within the nominal range, and the power phase sequence is correctly connected.
- e) The power cables between the indoor and outdoor units are correctly connected.
- f) The refrigerant piping system has passed a pressure decay test and shows no leaks.
- g) Verify that the main power supply voltage deviation does not exceed 10%, and the main control board voltage remains within 24V AC $\pm 10\%$.

1) Power Supply and Instrumentation Check

Before initial startup, check if the electrical distribution capacity matches the unit's power rating and if the selected cables can handle the unit's maximum operating current.

Check if the power supply matches the requirements specified on the unit's nameplate.

Check whether all terminal connections in the electrical control box are tightened (connections may loosen due to long-distance transportation and handling). If loose, retighten them. Failure to do so may damage electrical components (e.g., transformer, contactor) and the compressor. Verify that all electrical instruments and components are correctly installed, complete, and functional.

Use a multimeter to carefully inspect all electrical wiring, ensuring correct and proper installation. Use a megohmmeter to measure and confirm no short circuits to the chassis. Check that the ground wire is correctly installed and the insulation resistance to ground is greater than 2 M Ω . Verify that the power cables meet the capacity requirements.

Check whether a circuit breaker switch is installed on the power supply line feeding the unit.

2) Refrigerant System Check

Check if the high and low pressure setting values are normal.

For initial startup or after prolonged shutdown, energize the unit 12-24 hours in advance to preheat

the compressor.

Check the refrigerant charge level. Under full load, if bubbles are visible in the sight glass, it indicates insufficient refrigerant, requiring additional charge.

Check if the compressor wiring is correct. The compressor should start normally.

7.4 Unit Commissioning (Evacuation, Refrigerant Charging, etc.)

Units are shipped from the factory either pre-charged with refrigerant or pressurized with nitrogen, identifiable via labels on the shut-off valves or connections. For units not pre-charged with refrigerant, evacuation must be performed before charging.

1) Evacuation

Release the high-pressure nitrogen from the indoor and outdoor units to the outdoors (for units not factory-charged with refrigerant). Open all solenoid valves, expansion valves, shut-off valves, service valves, and other valve components.

Evacuate the refrigerant piping system to -0.1 MPa. Connect the compound gauge hoses to the service valves for evacuation. For units with a sight glass, the indicator should show green (to ensure vacuum and drying, employ the refrigerant purge method at least twice, performing repeated evacuations).

Initially, the vacuum pump noise will be loud, and white "smoke" may be emitted from the exhaust. If "white smoke" persists after 10 minutes, this might indicate poor sealing of the refrigerant system or excessive residual refrigerant/moisture; continue observing for another 10 minutes.

After 20 minutes, the pressure gauge needle should be in the negative value range, and the vacuum pump noise should be quieter. Repeatedly open and close the gauge valve several times. After closing the valve, the gauge needle position and pump noise should show no significant change; otherwise, the refrigerant system might have poor sealing.

After confirming no leaks in the refrigerant system, the evacuation time should generally not be less than 2 hours. The final vacuum pump reading should not exceed 60 Pa, or the low-pressure gauge needle should reach -76 cmHg. The moisture indicator in the sight glass should display dry.

After evacuation is complete, close the gauge manifold valves and all system valves. Turn off the vacuum pump. Without disconnecting the hoses, perform a pressure hold test for 1 hour. Pressure should not rise significantly, and the pressure value should not exceed 80 Pa. If the pressure rises, it indicates a leak. Locate and repair the leak.

2) Preliminary Refrigerant Charge



- Before charging, ensure that the hose connected to the refrigerant cylinder is secured.

a) After confirming the refrigerant system is leak-free and the vacuum level meets requirements, begin charging refrigerant immediately.

b) Charge refrigerant through the low-pressure service valve. Place the refrigerant cylinder upside down during charging.

c) Initially charge a portion of the refrigerant, then stop. Record the mass of refrigerant charged.

d) After preliminary charging is complete, close the gauge manifold and refrigerant cylinder valves.

e) Energize the unit, start the unit in cooling mode. When the unit is running, a low-side pressure between 6~8 kg/cm²G and a high-side pressure around 22~24 kg/cm²G indicate that charging is complete.

3) Additional Refrigerant Charge

During engineering installation, if the single-line piping length from the indoor unit to the outdoor unit exceeds 10 meters, additional refrigerant and compressor oil must be added to the standard charge for the extended piping to ensure normal system operation.

Formula for calculating additional refrigerant amount:

Additional Refrigerant (g) = Total Extended Liquid Line Length (m) × Refrigerant Addition per Meter of Liquid Line (g/m).

Where: Refrigerant Addition per Meter of Liquid Line (g/m) is shown in Table 7.1 below.

Table 7.1 Refrigerant Addition per Meter of Liquid Line

| Copper Pipe Specification (mm) | Refrigerant Addition per Meter of Liquid Line (g/m) | Copper Pipe Specification (mm) | Refrigerant Addition per Meter of Liquid Line (g/m) |
|--------------------------------|---|--------------------------------|---|
| φ9.52 | 55 | φ12.7 | 100 |
| φ15.88 | 150 | φ19.1 | 250 |
| φ22.2 | 305 | φ28.6 | 500 |

Total Extended Liquid Line Length (m) = Total Liquid Line Length (m) - 10 m.

If no compressor oil has leaked, adding oil is unnecessary. If oil leakage has occurred, contact the supplier to confirm the amount to add.

7.5 Pre-Energization Check

Confirm that wiring has been completed according to the electrical diagrams and inspected.

Confirm that the input power supply voltage and frequency are within the nominal range, and the power phase sequence is correct.

Confirm that the airflow inlet and outlet of the outdoor unit are unobstructed.

Check the sealing of the entire unit cabinet and seal any air leaks.

7.6 Unit Commissioning and Initial Startup

Note: During commissioning and initial startup, the unit must be handled solely by our company's technical personnel or authorized professionals. The content of this section is for reference only.

7.7 Main Window

1) After startup, the main window is displayed. View the current supply air temperature, return air humidity, current set temperature, and set humidity via the main window.

2) The navigation area is on the left side of the page. Press the corresponding buttons in the main menu of the navigation area to switch to the respective interface.

3) When the unit operates in Local Mode, press the On/Off button to complete the operation. If the unit operates in CoWork Mode or Time Schedule Mode, the system automatically determines the On/Off status. In this case, pressing the On/Off button will prompt "Exit CoWork Mode or Time Schedule Mode?" on the panel. Press "Confirm" to return to Local Mode for manual On/Off control. Press "Exit" to close the prompt without changing the On/Off state.

4) The main display interface contains a temperature adjustment gauge and a humidity adjustment gauge. Each gauge has three pointers: the largest white pointer indicates the current temperature/humidity value; the thin red pointer indicates the upper setpoint limit; the thin blue pointer indicates the lower setpoint limit.

5) Fan Status: No fan icon is displayed when no fans are running. The fan icon rotates when fans are operating, simultaneously displaying the fan output as a percentage of the full output.

6) Cooling Status: When the unit is in Cooling Mode, the cooling icon changes size, simultaneously displaying the cooling PID output percentage.

7) Dehumidification Status: When the unit is in Dehumidification Mode, the dehumidification icon changes size, simultaneously displaying the dehumidification PID output percentage.

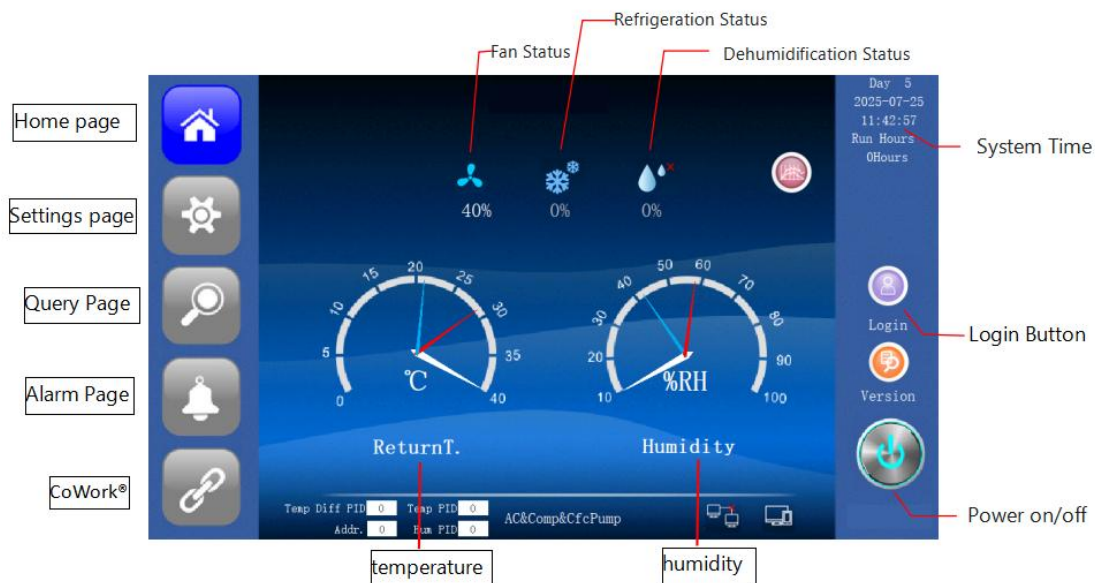





Figure 7.2 Main Display Interface

7.8 Operating Modes

The unit has three operating modes (indicated in the lower right corner): The icon  indicates the unit is operating in Local Mode, the icon  indicates CoWork Mode, and the icon  indicates Time Schedule Mode.

7.9 Host Computer Communication Status

When the mainboard is communicating with the host computer, the icon  is displayed below. The icon is hidden when communication is interrupted.

7.10 Login Button

Without logging in, users can view system parameters and factory settings but do not have permission to modify them. Login is required for modifications. Press the Login button to enter the login interface.

User Group (Password: 1234): For general daily operations, allows temperature and humidity parameter settings.

Select the user group to log in from the username field and enter the password. Press the Enter key to confirm the password, then press the Confirm key to log in successfully.

7.11 Parameter Settings

Press the "Parameter Settings" button in the main menu to enter the parameter settings interface. Upon initial power-up, all controller parameters are automatically set to factory defaults. Users can modify these parameters within the allowable ranges via the respective parameter submenus to achieve the optimal system operating environment and control requirements for the specific site. Press the corresponding submenu button to enter the parameter settings for that category. Press the corresponding input field to enter parameters directly, or use the Increase (+) and Decrease (-) keys to modify parameter values. The meaning, factory default value, and settable range for each parameter are explained below by category.

1) Temperature & Humidity Control

Press the "Temperature & Humidity Control" submenu to enter the temperature and humidity parameter settings page. Before setting these parameters, confirm whether the air conditioner is controlled based on supply air temperature or return air temperature. Select the buttons at the bottom of the "Temperature & Humidity Control" page to enter the corresponding page for parameter setting.

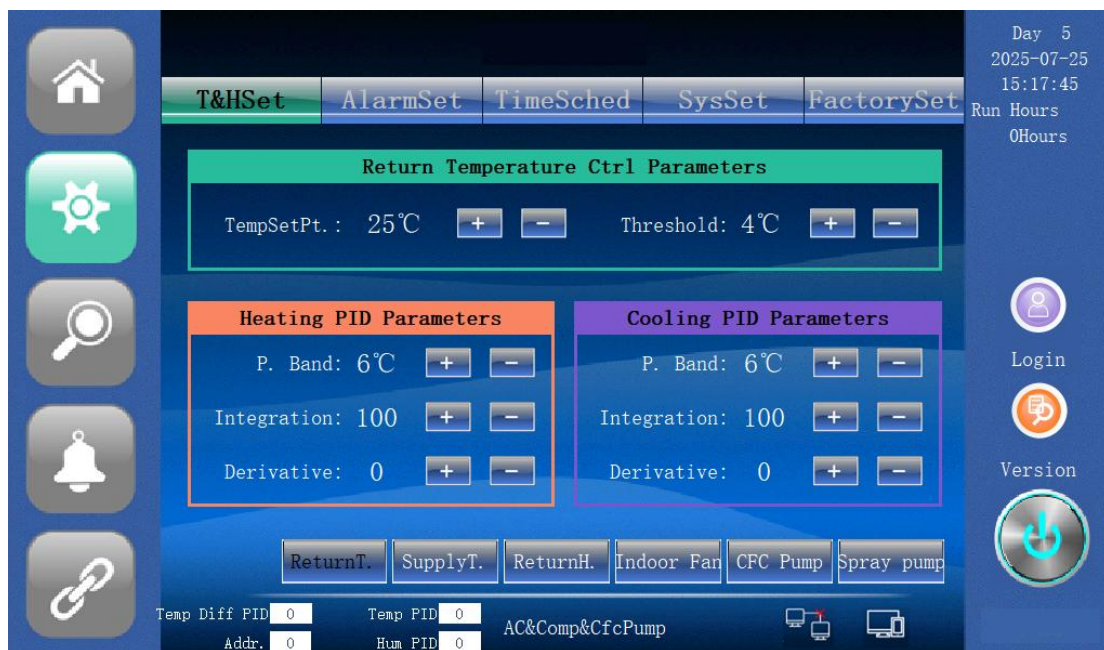

Figure 7.3 Temperature Parameter Settings

Table 7.2 Temperature & Humidity Control Parameters

| Parameter Name | Range | Default | Meaning & Notes |
|------------------------------------|-----------|---------|--|
| Temperature Setpoint | 10°C~30°C | 25°C | Desired temperature value (commonly known as setpoint). When "Fan Control Option [Chilled Water]" is set to "Supply Air Temperature" and "PDU Control Enable" is ON, the "Return Air Temperature Setpoint" also needs to be set. This value will serve as the temperature reference point for PDU control to shut down the chiller. |
| Temperature Differential | 1°C~10°C | 4°C | When the absolute difference between the current temperature and the setpoint exceeds this value, output 100% analog signal for "Cooling/Heating". |
| Heating Proportional Band | 1°C~20°C | 6°C | Heating proportional coefficient for PID control. |
| Heating Integral Constant | 0~200 | 100 | Heating integral time for PID control. |
| Heating Derivative Constant | 0~200 | 0 | Heating derivative coefficient for PID control. |
| Cooling Proportional Band | 1°C~10°C | 6°C | Cooling proportional coefficient for PID control. |
| Cooling Integral Constant | 0~200 | 0 | Cooling integral time for PID control. |
| Cooling Derivative Constant | 0~200 | 0 | Cooling derivative coefficient for PID control. |
| Humidity Setpoint | 20%~85% | 50% | Desired humidity value (commonly known as setpoint). |
| Humidity Threshold | 1%~15% | 8% | When the absolute difference between the current humidity and the setpoint exceeds this threshold, output 100% analog signal for "Dehumidification/Humidification". |
| Humidification Proportional Band | 3%~40% | 10% | Humidification proportional coefficient for PID control. |
| Humidification Integral Constant | 0~200 | 100 | Humidification integral time for PID control. |
| Humidification Derivative Constant | 0~200 | 0 | Humidification derivative coefficient for PID control. |

| | | | |
|--------------------------------------|--------|-----|--|
| Dehumidification Proportional Band | 3%~40% | 10% | Dehumidification proportional coefficient for PID control. |
| Dehumidification Integral Constant | 0~200 | 100 | Dehumidification integral time for PID control. |
| Dehumidification Derivative Constant | 0~200 | 0 | Dehumidification derivative coefficient for PID control. |

- Integral time unit is 100 seconds.

2) Fluorine Pump Parameters

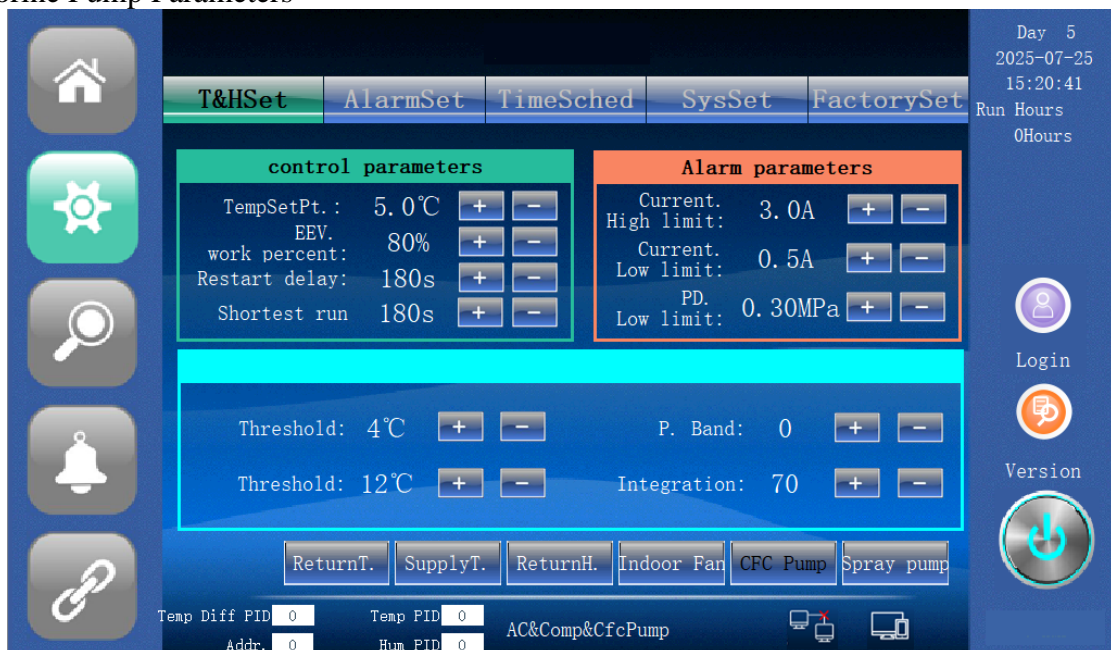

Figure 7.4 Fluorine Pump Parameter Settings

Table 7.3 Fluorine Pump Control Parameters

| Parameter Name | Range | Default | Meaning & Notes |
|-----------------------------|-----------|---------|---|
| Temperature Setpoint | -5°C~30°C | 5°C | When the outdoor temperature is below this setpoint, the fluorine pump starts preferentially over the compressor. |
| Fluorine Pump EEV Opening | 0%~100% | 80% | Fixed opening of the fluorine pump electronic expansion valve. |
| Fluorine Pump Restart Delay | 0s~180s | 180s | Minimum off duration for the fluorine pump before it can restart. |
| Fluorine Pump | 0s~600s | 180s | Minimum on duration for the fluorine |

| | | | |
|---------------------------|------------|--------|--|
| Minimum Run Time | | | pump once started. |
| Current High Limit | 0A~5A | 3A | Alarm triggered if fluorine pump current exceeds this value. |
| Pressure Diff Low Limit | 0 Mpa~5Mpa | 0.3Mpa | Alarm triggered if fluorine pump pressure difference falls below this value. |
| Spray Pump Start Pressure | 0 Mpa~5Mpa | 2Mpa | When starting the fluorine pump, if the condensing pressure is higher than this value, start the spray pump. |
| Differential | 0 Mpa~5Mpa | 0.3Mpa | The absolute difference between the actual condensing pressure and the spray pump start pressure, used to start/stop the spray pump. |

3) Alarm Parameters

Press the "Alarm Parameters" submenu to enter the alarm parameter settings page.

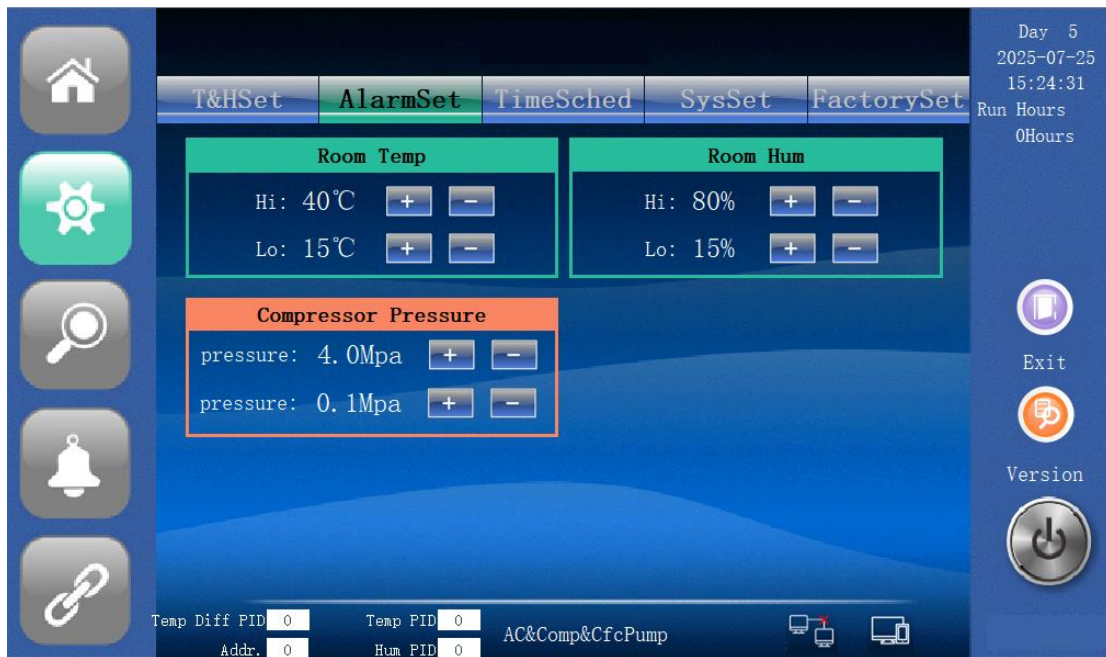

Figure 7.5 Alarm Parameter Settings Interface

Table 7.4 Alarm Parameters

| Parameter Name | Range | Default | Meaning & Notes |
|------------------------|------------|---------|--|
| Temperature High Limit | 20°C~50 °C | 40°C | Triggers a high-temperature alarm when the temperature exceeds this limit. |

| | | | |
|-----------------------|---------------|------|---|
| Temperature Low Limit | 10°C~30 °C | 15°C | Triggers a low-temperature alarm when the temperature falls below this limit. |
| Humidity High Limit | 70%~95% | 80% | Triggers a high-humidity alarm when the humidity exceeds this limit. |
| Humidity Low Limit | 10%~50% | 15% | Triggers a low-humidity alarm when the humidity falls below this limit. |

4) Time Schedule Control Parameters

When the air conditioner controller operates in Time Schedule Mode, four time points can be set as action points each day. Each action point has three action types: Set to "0" for Shutdown, "1" for Startup, and "2" for Relax operation. Upon power-up and operation, the controller automatically determines the current time relative to the two nearest action points and executes the action corresponding to the earlier time point. If the current time is before all four action points of the current day, the controller executes the action of the last action point from the previous day. This ensures the "Time Schedule Mode" can control the air conditioner's operation at any time. The Time Schedule parameter settings interface is as follows:

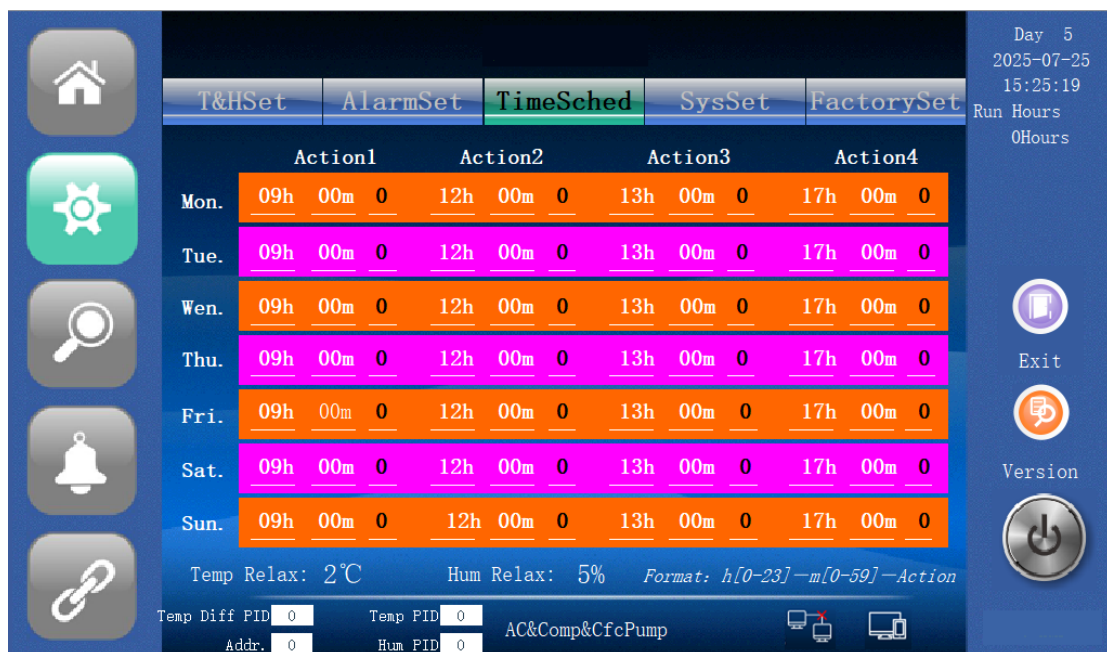

Figure 7.6 Time Schedule Interface

When the touchscreen starts up, the clock chip on the main controller board synchronizes with the touchscreen's clock. Subsequently, the two clocks synchronize every twenty minutes. There is a "Clock Sync" button at the top of the Time Schedule interface; pressing this button also initiates an immediate clock synchronization.

5) System Parameters

Press the "SysSet" submenu to enter the system parameter settings page.

There are four pages of system parameters:

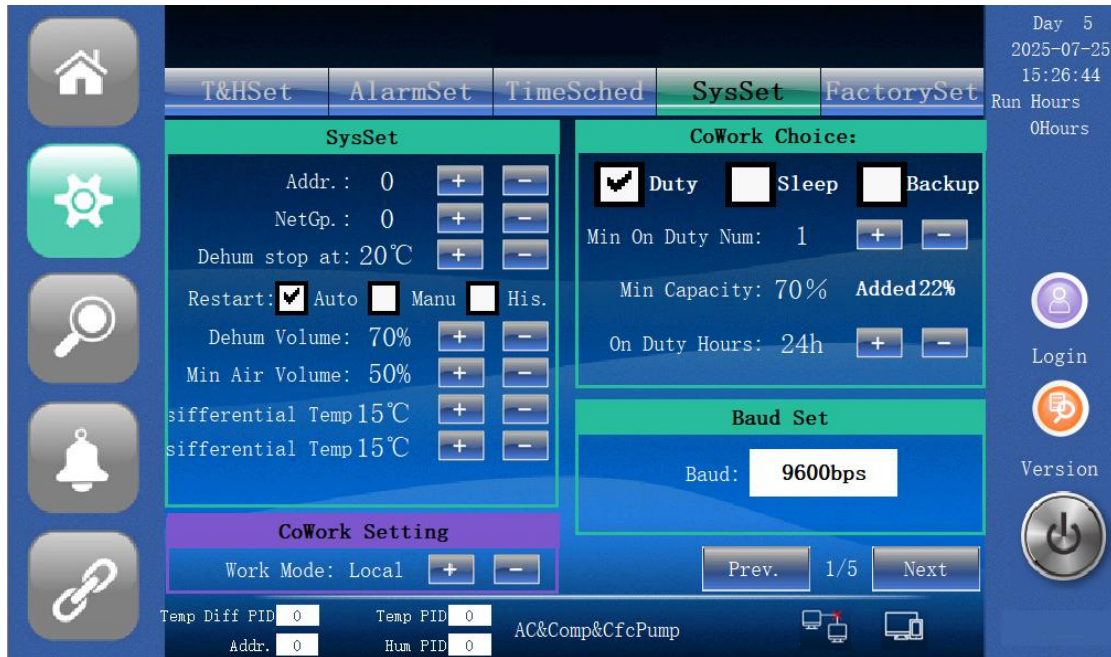

Figure 7.7 System Parameters Page 1

Table 7.5 System Parameter Settings 1

| Parameter Name | Range | Default | Meaning & Notes |
|-----------------------------------|----------------------|---------|--|
| Network Group No. | 0~7 | 0 | Network (CoWork) Group Number |
| Unit No. | 1~32 | 1 | Unit Number |
| Temperature Priority Value | 10°C~25°C | 15°C | If the temperature is less than this setpoint, dehumidification is disabled. |
| Auto Restart after Power Failure | Auto, Manual, Memory | Auto | In Local Mode, if Auto Start is enabled, the unit powers on automatically after power is restored. In Memory Mode, the unit maintains its pre-power failure state. |
| EC Fan Dehumidification | 40%~100% | 70% | EC fan output percentage in Dehumidification Mode. |
| EC Fan Minimum Airflow | 40%~60% | 50% | Minimum operating airflow for the EC fan. |
| Shutdown Differential Temperature | 0°C-30°C | 15°C | The compressor and fluorine pump shut down when the temperature is below the setpoint minus this differential temperature. |
| Set Control Mode | Three Modes | Local | Three modes available: "Local Mode", |

| | | | |
|-----------------------------|------------------|---------|---|
| | | | "Time Schedule Mode", "CoWork Mode". |
| Minimum On-duty Units Count | 1~32 | 1 | Minimum number of on-duty units. |
| Minimum On-duty Capacity | 0~100 | 50 | Minimum on-duty capacity as a percentage of the total capacity of all CoWork units. |
| On-duty Unit Rotation Hours | 2H~240H | 24H | Hours before switching on-duty units. |
| Baud Rate | 4800bps-38400bps | 9600bps | Baud rate for the J8-Modbus RS485 3/4 external communication interface. |

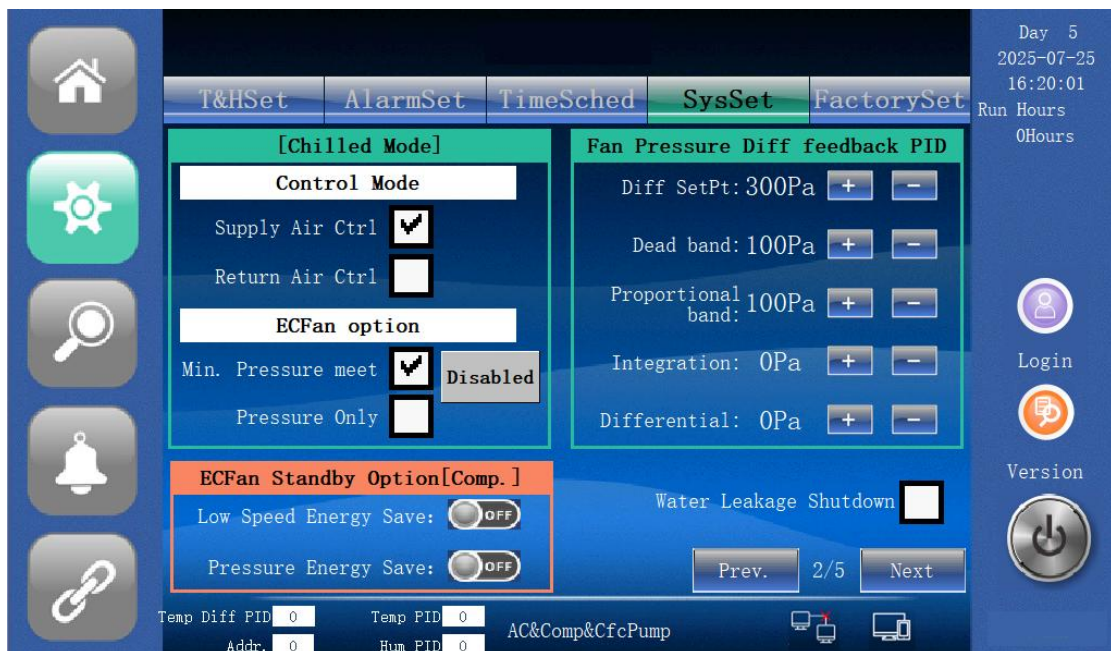

Figure 7.8 System Parameters Page 2

Table 7.6 System Parameter Settings 2

| Parameter Name | Range | Default | Meaning & Notes |
|------------------------------------|--|-------------------------|---|
| Fan Control Option [Chilled Water] | Supply Air Temp Control, Return Air Temp Control | Return Air Temp Control | Select control based on Return Air Temperature or Supply Air Temperature. |
| Fan Control Option [Compressor] | 2 Options | Disabled | Energy Saving Mode, Differential Pressure Mode. |
| Supply Air Pressure Setpoint | 100-1000Pa | 650Pa | Setpoint for fan differential pressure control. |
| Supply Air Pressure | 20~250Pa | 60Pa | Threshold parameter for fan |

| | | | |
|---|----------|------|--------------------------------|
| Differential | | | differential pressure control. |
| Supply Air Pressure Proportional Band | 20~250Pa | 60Pa | Proportional coefficient. |
| Supply Air Pressure Integral Constant | 0 ~250 | 0 | Integral coefficient. |
| Supply Air Pressure Derivative Constant | 0~250 | 0 | Derivative coefficient. |

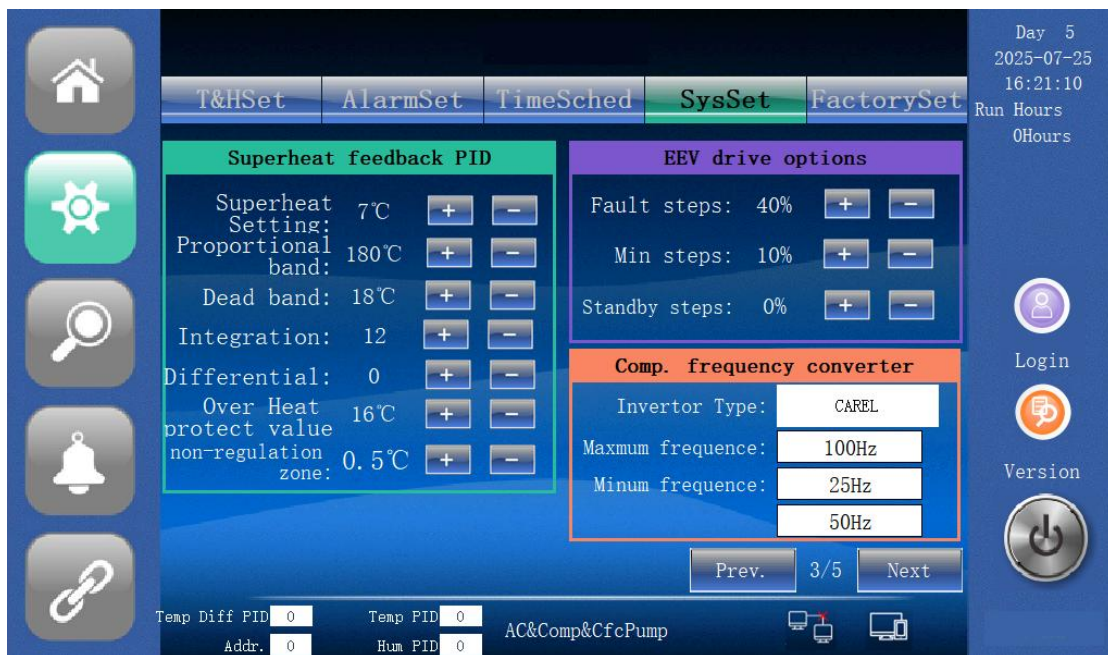

Figure 7.9 System Parameters Page 3

Table 7.7 System Parameter Settings 3

| Parameter Name | Range | Default | Meaning & Notes |
|---|-----------|---------|---|
| Superheat PID Control Setpoint | 0°C-25°C | 7°C | Superheat control setpoint. |
| Superheat PID Control Proportional Band | 0°C-200°C | 180°C | Superheat control proportional coefficient. |
| Superheat PID Control Differential | 0°C-18°C | 18°C | Superheat control threshold. |
| Superheat PID Control Integral Constant | 0-200 | 12 | Integral coefficient. |
| Superheat PID Control Derivative Constant | 0-200 | 0 | Derivative coefficient. |

| | | | |
|-----------------------|------------|-------|---|
| Inverter Type | \ | CAREL | Six inverter models: CAREL, Emerson EVD, A120, MS300, BSP, CA120. |
| Frequency Upper Limit | 60Hz-120Hz | 100Hz | Maximum output frequency of the inverter. |
| Frequency Lower Limit | 0Hz-60Hz | 25Hz | Minimum output frequency of the inverter. |

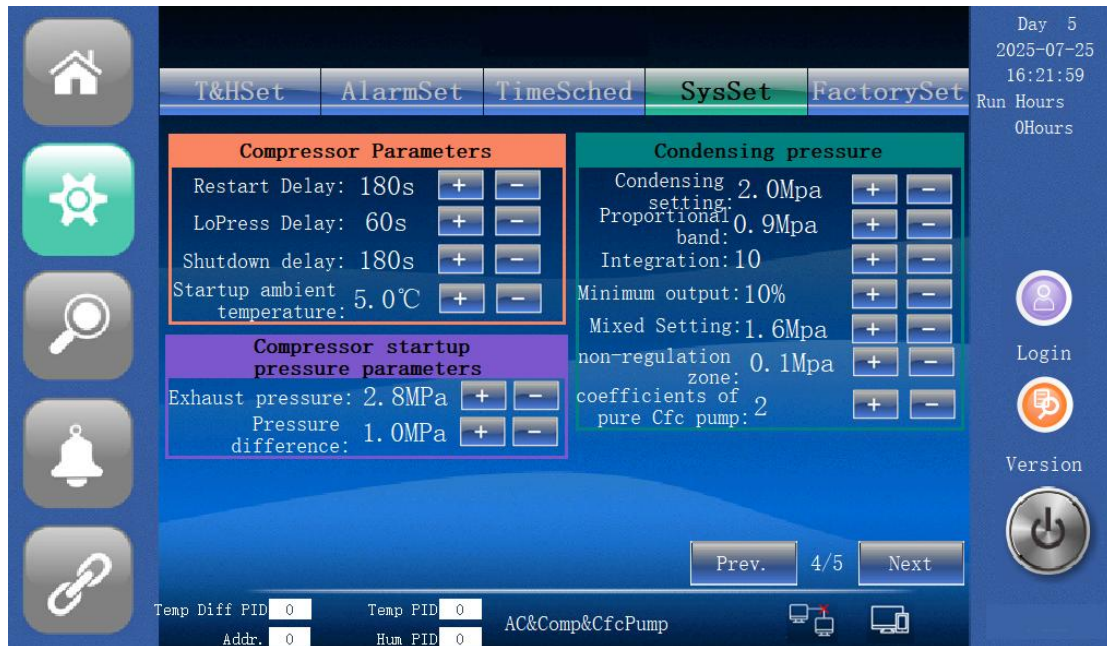

Figure 7.10 System Parameters Page 4

Table 7.8 System Parameter Settings 4

| Parameter Name | Range | Default | Meaning & Notes |
|-------------------------------|---------------|---------|---|
| Compressor Restart Delay | 60S~180S | 120S | Delay required before the compressor can restart after shutdown. |
| Compressor Low Pressure Delay | 40S~120S | 80S | Delay time for low-pressure detection after compressor startup. |
| Condensing Pressure Setpoint | 1-3Mpa | 1.6Mpa | Condensing pressure setpoint. |
| Proportional Band | 0.1-1.5Mpa | 0.9Mpa | Condensing pressure proportional band control. |
| Integral Constant | 0-200 | 10 | Condensing pressure integral control. |
| Minimum Output | 0-50% | 10% | Minimum output of the condensing pressure analog channel. |
| Chilled Water Switchover Temp | 0°C~20°C/SKIP | 7°C | Setpoint for switching to/from chilled water cooling mode. When set to 20/SKIP, |

| | | | |
|--------------------------------|------------|-----|---|
| Setpoint | | | this condition check is skipped (always true). |
| FreeCooling Enable Temperature | -40°C~10°C | 7°C | Setpoint for the outdoor temperature that allows FreeCooling to be enabled. |

7.12 Information Query

Press the "Information Query" button in the main menu to enter the information query interface. You can query four types of information: Equipment Status, Operating Cumulative Hours, Analog Inputs, and Port Inputs. Manual control of various equipment can also be performed from this interface.

1) Device Status

Press the "Device" submenu to view the equipment status interface, which shows whether each device in every module is activated.

When superheat control is enabled, the dehumidification valve function switches to a hot gas bypass valve, displayed as "Bypass Valve".

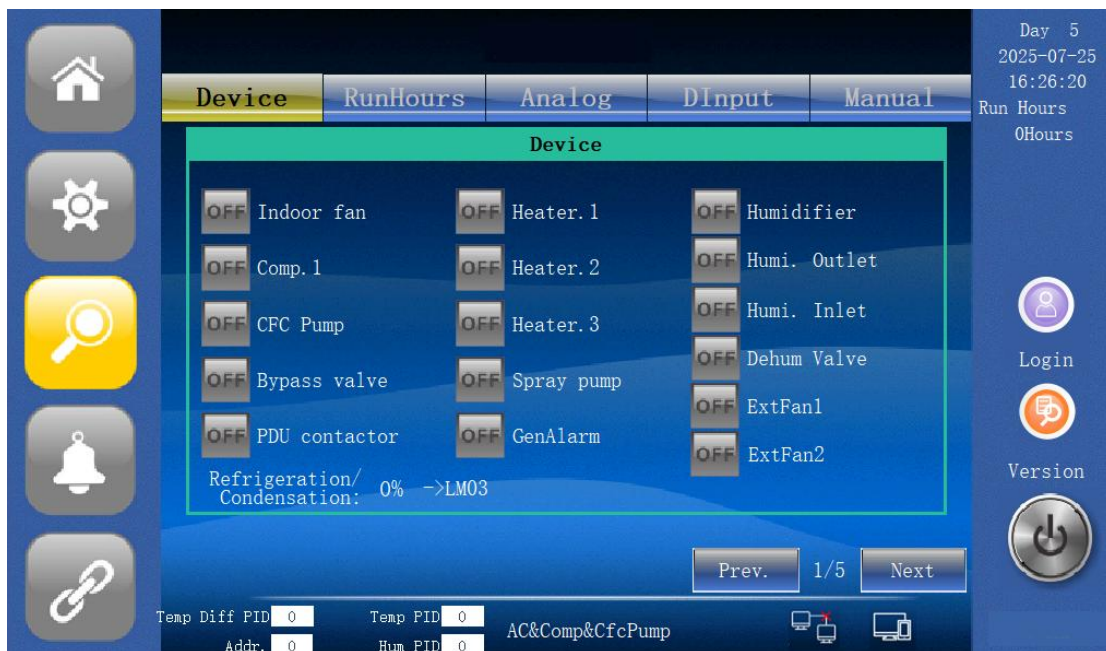

Figure 7.11 Device Status Interface

2) Operating Cumulative Time

Press the "Runhours" submenu to view the cumulative operating hours interface, which shows the total running time for each device.

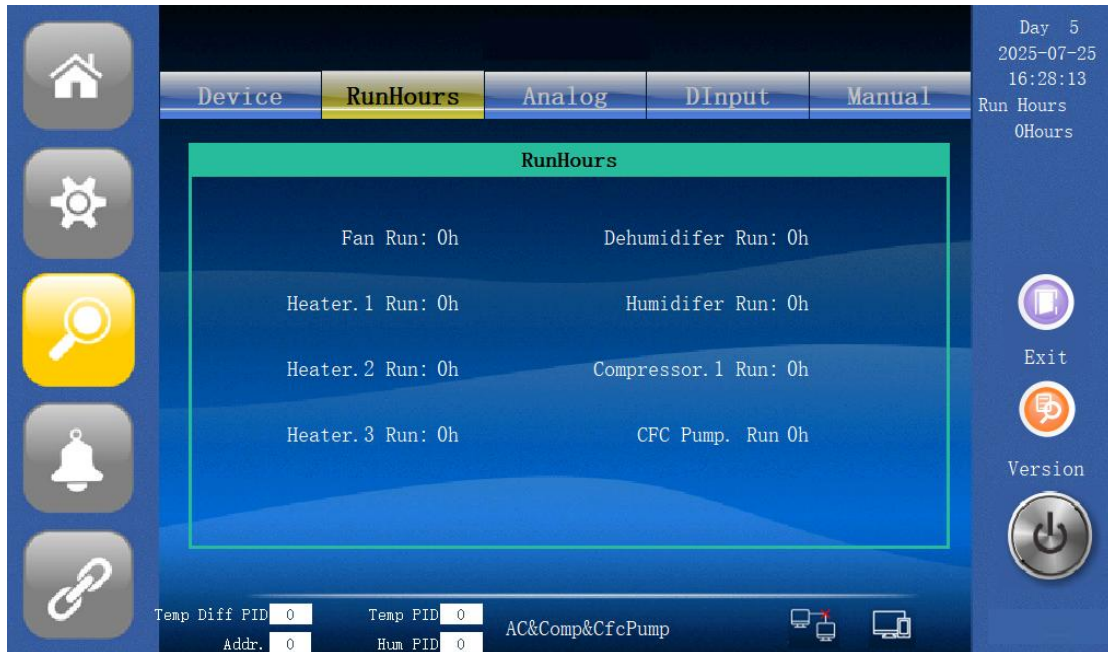

Figure 7.12 Operating Cumulative Time Query Interface

7.13 Analog Inputs

Press the "Analog" submenu to view the analog inputs interface, which displays the analog data collected by each module.

When a temperature item displays "3276.6°C" or shows no value, it indicates that the corresponding temperature sensor is not connected or has failed.

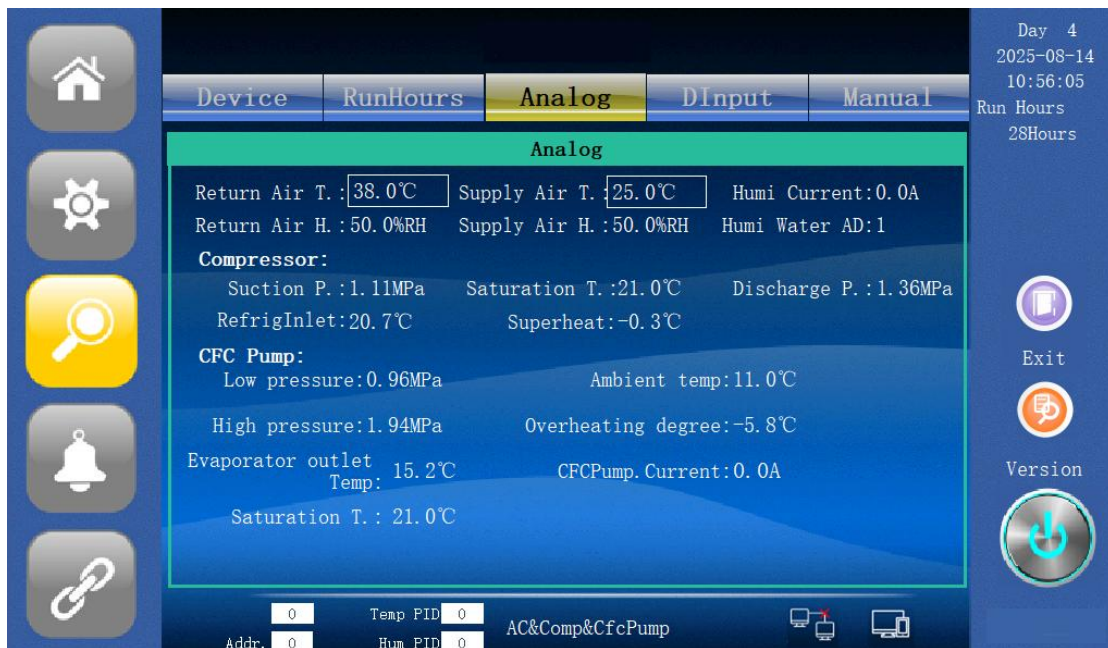

Figure 7.13 Analog Inputs Query Interface

7.14 Alarm Menu

Press the "Alarm Menu" button in the main menu to query alarm information. You can check if there are any alarms for the devices in each module.

1) Current Alarms

Press the "Alarms" submenu to view devices that are currently in alarm. The interface includes an "Alarm Reset" button. Pressing this button clears all alarm signals. However, if the alarm condition persists, the alarm signal will be triggered again. When an alarm signal is present, the buzzer on the mainboard sounds and the button appears. Pressing the button stops the buzzer. The buzzer will sound again when a new alarm occurs.



Figure 7.14 Current Alarms Query Interface

2) Alarm History

Press the "AlarmRecord" submenu to view the alarm history interface. It records historical alarm data. Use the "Next" and "Prev." buttons to navigate, and the "Refresh" button to update the current alarm data.

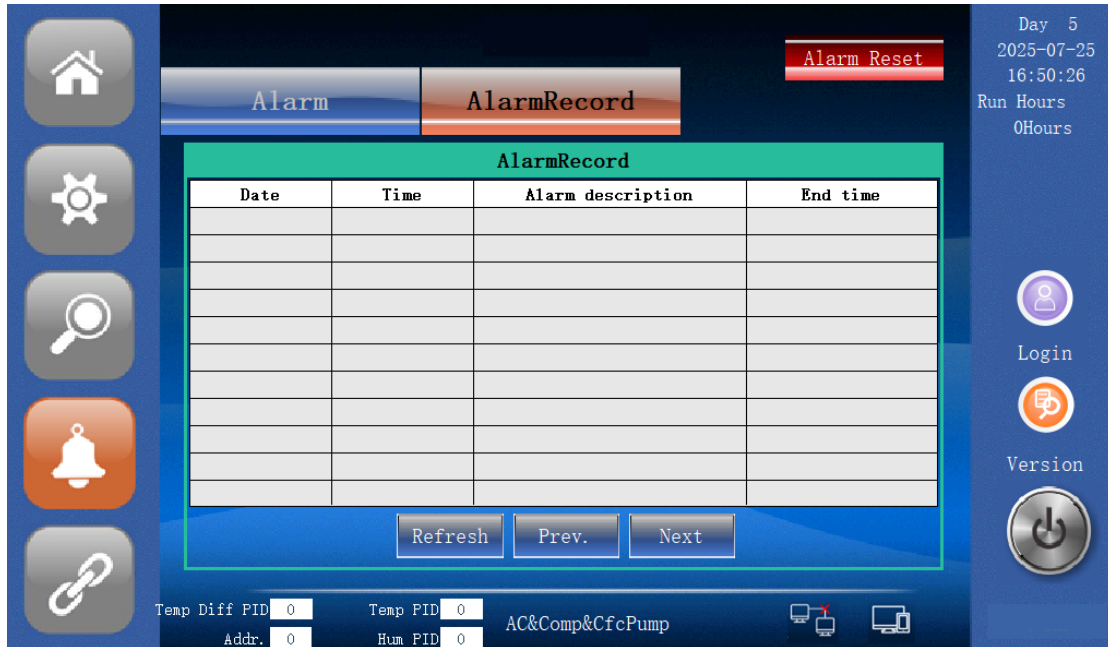

Figure 7.15 Alarm History Query Interface

Historical alarm data can be cleared. The function to clear alarm data is not available to users. Specific operation method: During the UI unit startup process, when the startup progress bar appears, press anywhere on the display. After hearing the buzzer sound, the "Startup Properties" window will appear. Click "File Operations", select the "Alarm Data" item, click "Delete Data", and click "OK" after successful deletion. Close the window and click "Restart". Operation complete.

7.15 Software Version Information & System Time Setting

Pressing the system time display area in any interface pops up the software version information and system time setting window.

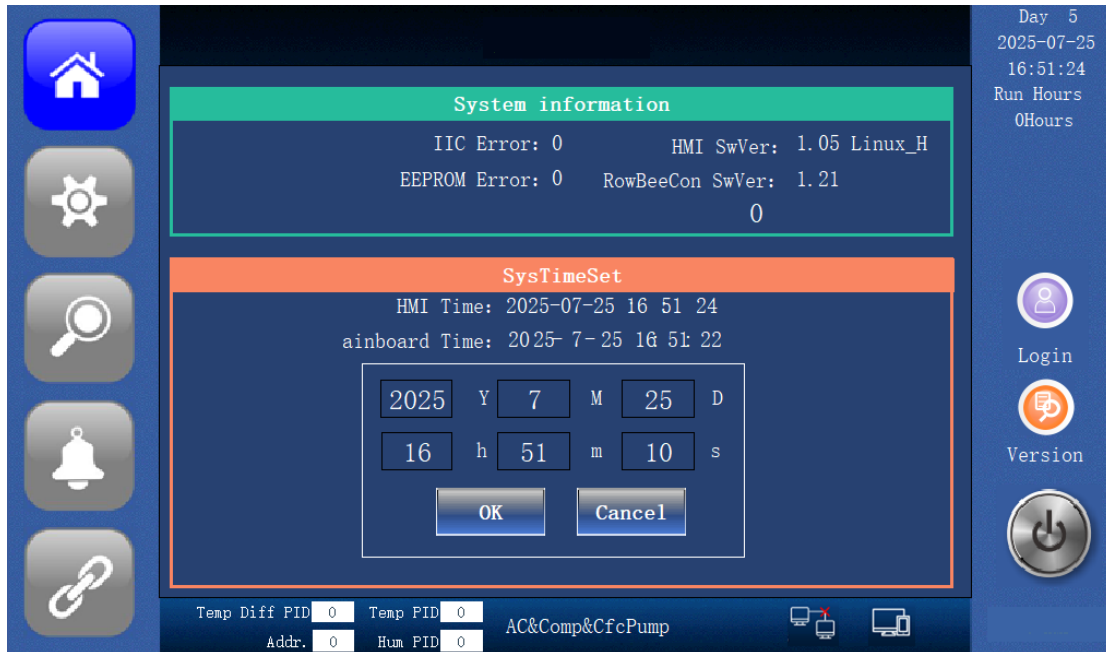

Figure 7.16 Software Version & Time Setting Interface

This window can be used to set the system date and time, and to view the main controller software version and HMI software version.

This interface also displays whether the system EEPROM and real-time clock chip are functioning normally.

7.16 MODBUS RTU Communication Protocol Implementation

1) Scope

The air conditioner controller supports the ModBus RTU communication protocol (ModBus is a registered trademark of Modicon Inc.). The communication protocol details the controller's input and output commands, messages, and data for use and development by third parties.

2) Physical Interface

The communication port connected to the UI panel uses an industrial standard serial RS485 communication port. The fixed UI port address is 119.

The control system CAN-BUS network enables point-to-point master-slave communication between the host computer and any air conditioner host device on the network via a CAN/RS485 gateway. Host device address = Network Group Number * 32 + Unit Number. (Note: Address 0 is reserved)

Data format: 1 start bit, 8 data bits, 1 stop bit, no parity. Default data transmission rate is 9600 b/s.

3) Communication Method

MODBUS RTU uses a master-slave structure. Messages and data are effectively transmitted between the UI panel/host computer and the air conditioner controller mainboard, allowing the UI

panel/host computer to access relevant data of the BeeConPlus air conditioner controller and send control commands.

MODBUS RTU Communication Protocol Details:

a) Data Byte Format Description

Information is transmitted asynchronously, in bytes, with each byte consisting of 8 binary bits:

Table 7.9 Communication Format

| | |
|--------------|----------|
| Start Bit | 1 bit |
| Data Bits | 8 bits |
| Parity Bit | None |
| Stop Bit | 1 bit |
| Flow Control | None |
| Baud Rate | 9600 bps |

b) Data Frame Structure Description

The main communication flow is as follows:

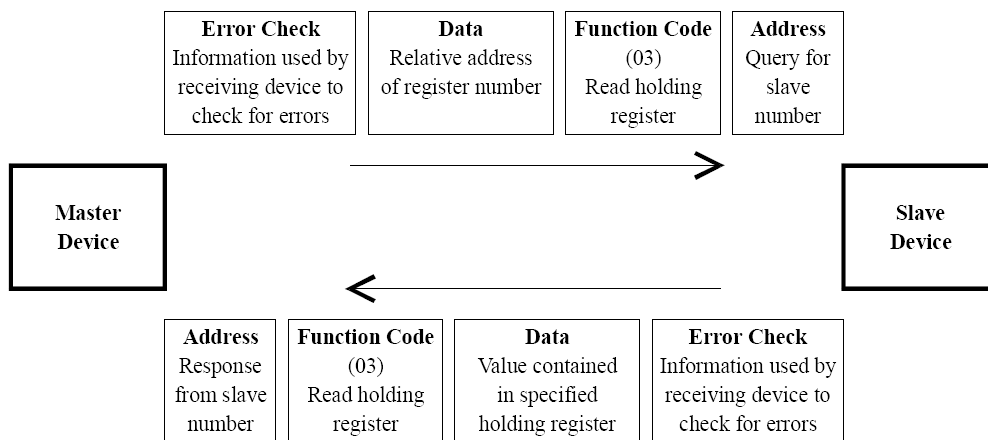

Figure 7.17 Communication Flow

Each data frame is structured as follows: (RTU Mode)

Table 7.10 Frame Structure

| Address Field | Function Code | Data Field | CRC Check |
|---------------|---------------|------------|-----------|
| 8 bits | 8 bits | N * 8 bits | 16 bits |

1. Address Field

The Address Field is the first byte (8 bits) of each data frame, identifying the subordinate device (with a user-set address) that should receive the message from the master. Each slave must have a unique address, and only the slave matching the address will respond. When a slave responds, its response data starts with its own address. The address sent by the master indicates the target slave, and the address

returned by the slave indicates the source of the response. The address range is 0x01—0xFF, where 0xFF is the broadcast address (devices must not return data after processing a broadcast command).

2. Function Code

The Function Code is the second byte in each data frame transmission. The ModBus communication protocol defines function codes 1, 2, 3, 4, 5, 6, 7, 11, 12, 15, 16, 17, 20, 21, 22, 23, 24. The BeeConPlus air conditioner controller uses only a subset of these. In a master request, the function code tells the slave what action to perform. In the slave response, the returned function code echoes the one sent by the master, indicating the slave has responded and performed the requested action.

MODBUS Function Codes Used by the Air Conditioner Controller

Table 7.11 MODBUS Function Codes

| Function Code | | Definition | Description |
|---------------|-----|------------------------|--|
| 1 | 01H | Read Coil Status | Reads the status of output relays (coils). |
| 2 | 02H | Read Input Status | Reads the status of discrete inputs. |
| 3 | 03H | Read HoldingRegisters | Reads values from holding registers. |
| 4 | 04H | Read Input Registers | Reads values from input registers (read-only). |
| 5 | 05H | Force Single Coil | Writes a single output relay (coil) state. |
| 6 | 06H | Preset Single Register | Writes a single holding register value. |
| 15 | 0FH | Force Multiple Coils | Writes multiple output relay (coil) states. |
| 16 | 10H | Load MultipleRegister | Writes multiple holding register values. |

3. Data Field

The Data Field contains the information that specifies what data the slave should return or what action it should perform. This information can be data, reference addresses, etc.

4. Error Check Field (16-bit CRC Check)

The master or slave can use the check code to determine if the received information is correct. Due to electrical noise or other interference, errors can occur during transmission. The Cyclical Redundancy Check (CRC) allows the master or slave to detect errors in the communication data. Erroneous data can be discarded (whether sent or received), enhancing system security and efficiency.

The MODBUS communication protocol CRC (Redundancy Cyclical Code) comprises 2 bytes (16 bits). The CRC value is calculated by the transmitting device (master) and placed at the end of the transmission frame (CRC high byte first). The receiving device (slave) recalculates the CRC of the received message and compares it with the received CRC. If they do not match, an error has occurred.

Calculation Steps:

Preload a 16-bit register with FFFFh (all ones). Call this the CRC register.

XOR the first 8-bit byte of the message with the low-order byte of the CRC register, storing the

result in the CRC register.

Shift the CRC register right one bit (towards the LSB), filling the MSB with zero. Check the ejected LSB (note: this refers to the bit shifted out, not the new LSB after shifting).

If the ejected LSB was 0: Repeat step 3 (shift again). If the ejected LSB was 1: XOR the CRC register with the polynomial A001h (1010 0000 0000 0001 binary).

Repeat steps 3 and 4 until 8 shifts have been performed. This completes processing one byte.

Repeat steps 2 through 5 for the next byte of the message.

The final content of the CRC register is the CRC value.

4) Transmission Formats

a) Command Message Formats

1. Read Coil Status (Function Code 01H)

Reads bits, primarily used in this system to read the power on/off status.

Table 7.12

| Address | Func Code | Starting Address | | Quantity | | CRC | |
|---------|-----------|------------------|-----|----------|-----|------|-----|
| 01 | 01 | High | low | High | Low | High | Low |

Response:

Table 7.13

| Address | Func Code | Byte Count | Data | CRC | |
|---------|-----------|------------|------------------------------|------|-----|
| 01 | 01 | N | Data (Coil Status 8) 1..N | High | Low |

Communication Example:

Request: Length: 0008, Data: 01 01 00 00 00 01 FD CA

Response: Length:0006, Data: 01 01 01 01 90 48

2. Read Input Status (Function Code 02H)

Reads bits, primarily used in this system to read the status of air conditioner components and operating states.

Table 7.14

| Address | Func Code | Starting Address | | Quantity | | CRC | |
|---------|-----------|------------------|-----|----------|-----|------|-----|
| 01 | 02 | High | low | High | Low | High | Low |

Response:

Table 7.15

| Address | Func Code | Byte Count | Data | CRC | |
|---------|-----------|------------|----------------------|------|-----|
| 01 | 02 | N | Data (Coil Status 8) | High | Low |

| | | | | | |
|--|--|--|------|--|--|
| | | | 1..N | | |
|--|--|--|------|--|--|

Communication Example:

Request: Length: 0008, Data: 01 02 00 00 00 07 39 C8

Response: Length: 0006, Data: 01 02 01 26 20 52

3. Read Holding Registers (Function Code 03H)

Reads holding registers, primarily used to read air conditioner setting parameters and the clock.

Table 7.16

| Address | Func Code | Starting Address | | Quantity | | CRC | |
|---------|-----------|------------------|-----|----------|-----|------|-----|
| | | High | low | High | Low | High | Low |
| 01 | 03 | High | low | High | Low | High | Low |

Response:

Table 7.17

| Address | Func Code | Byte Count | Data | CRC | |
|---------|-----------|------------|---------------------------|------|-----|
| 01 | 03 | N | Data (Coil Status 8) 1..N | High | Low |

Communication Example:

Request: Length: 0008, Data: 01 03 00 00 00 07 04 08

Response: Length: 0019, Data: 01 03 0E 00 09 00 08 00 1B 00 05 00 0F 00 37 00 15 17 4C

4. Read Input Registers (Function Code 04H)

Reads input registers. Register data in the data area are each two bytes, high byte first. Primarily used to read sensors, analog outputs, operating cumulative hours, and alarm status.

Table 7.18

| Address | Func Code | Starting Address | | Quantity | | CRC | |
|---------|-----------|------------------|-----|----------|-----|------|-----|
| | | High | low | High | Low | High | Low |
| 01 | 04 | High | low | High | Low | High | Low |

Response:

Table 7.19

| Address | Func Code | Byte Count | Data | CRC | |
|---------|-----------|------------|--|------|-----|
| 01 | 04 | 2N | Data1 (Coil Status 16)Data N (Coil Status 16) | High | Low |

Communication Example:

Request: Length: 0008, Data: 01 04 00 00 00 05 30 09

Response: Length: 0015, Data: 01 04 0A 00 01 01 09 01 F7 01 09 01 F7 E1 CD

5. Force Single Coil (Function Code 05H)

Writes a single coil. The data here is one byte, which can only be 0xFF 00 (ON) or 0x00 00 (OFF). 0xFF 00 represents startup, 0x00 00 represents shutdown.

Table 7.20

| Address | Func Code | Starting Address | | Data | | CRC | |
|---------|-----------|------------------|-----|------|-----|------|-----|
| 01 | 05 | High | low | High | Low | High | Low |

Response:

Table 7.21

| Address | Func Code | Starting Address | | Data | | CRC | |
|---------|-----------|------------------|-----|------|-----|------|-----|
| 01 | 05 | High | low | High | Low | High | Low |

Communication Example:

Request: Length: 0008, Data: 01 05 00 00 FF 00 8C 3A

Response: Length: 0008, Data: 01 05 00 00 FF 00 8C 3A

6. Preset Single Register (Function Code 06H)

Writes a single holding register, primarily used in this protocol to set a single variable parameter.

Table 7.22

| Address | Func Code | Address | | Data | | CRC | |
|---------|-----------|---------|-----|------|-----|------|-----|
| 01 | 05 | High | low | High | Low | High | Low |

Response:

Table 7.23

| Address | Func Code | Address | | Data | | CRC | |
|---------|-----------|---------|-----|------|-----|------|-----|
| 01 | 05 | High | low | High | Low | High | Low |

Communication Example:

Request: Length: 0008, Data: 01 06 00 00 07 D9 4A 60

Response: Length: 0008, Data: 01 06 00 00 07 D9 4A 60

7. Force Multiple Coils (Function Code 0FH)

Writes multiple coils based on the provided bits.

Table 7.24

| Address | Func Code | Starting Address | | Quantity | | Byte Count | CRC | |
|---------|-----------|------------------|-----|----------|-----|------------|------|-----|
| 01 | 15 | High | low | High | Low | N | High | Low |

Response:

Table 7.25

| Address | Func Code | Starting Address | | Quantity | | CRC | |
|---------|-----------|------------------|--|----------|--|-----|--|
| s | | | | | | | |

| | | | | | | | |
|----|----|------|-----|------|-----|------|-----|
| 01 | 15 | High | low | High | Low | High | Low |
|----|----|------|-----|------|-----|------|-----|

Communication Example:

Request: Length: 0010, Data: 01 0F 00 00 00 01 01 00 2E 97

Response: Length: 0008, Data: 01 0F 00 00 00 01 94 0B

8. Preset Multiple Registers (Function Code 10H)

Writes multiple holding registers.

Table 7.26

| Address | Func Code | Starting Address | | Quantity | | Byte Count | Data | CRC | |
|---------|-----------|------------------|-----|----------|-----|------------|----------------------------|------|-----|
| | | High | low | High | Low | | | High | Low |
| 01 | 16 | High | low | High | Low | 2N | Data(Coil Status 16) 1 ~ N | High | Low |

Response:

Table 7.27

| Address | Func Code | Starting Address | | Quantity | | CRC | |
|---------|-----------|------------------|-----|----------|-----|------|-----|
| | | High | low | High | Low | High | Low |
| 01 | 16 | High | low | High | Low | High | Low |

Communication Example:

Request: Length: 0023, Data: 01 10 00 00 00 07 0E 00 09 00 08 00 1B 00 05 00 10 00 00 00 3A 98 E6

Response: Length: 0008, Data: 01 10 00 00 00 07 81 CB

b) Exception Response

Illegal Function:

Table 7.28

| Slave Address | Function Code | Exception Code | CRC | |
|---------------|--------------------------|----------------|------|-----|
| | | | High | Low |
| 01 | 80H + Original Func Code | ERR | High | Low |

ERR:

01 Illegal Function

02 Illegal Data Address

03 Illegal Data Value

04 Illegal Quantity

05 CRC Error

8 Common Faults & Troubleshooting Methods

8.1 Fault Diagnosis and Handling of Each Component

Table 8.1 List of common faults and troubleshooting methods.

| No. | Fault Type | Cause Analysis | Solution |
|-----|-------------------------|--|--|
| 1 | Fan Won't Start | <p>A. No main power supply.</p> <p>B. Circuit breaker tripped or fuse blown.</p> <p>C. Overload, air switch tripped.</p> <p>D. Contactor not pulling in.</p> <p>E. Control board fault.</p> <p>F. Fan itself failed.</p> | <p>A. Check L1, L2, L3 rated voltage.</p> <p>B. Check main fan fuse and circuit breaker.</p> <p>C. Manually reset. Check average current.</p> <p>D. Check if the contactor control terminal has output according to wiring diagram.</p> <p>E. Check if the mainboard control terminal has output according to wiring diagram.</p> <p>F. Replace fan.</p> |
| 2 | Unit Not Working | <p>A. External power not supplied.</p> <p>B. Unit power not supplied.</p> <p>C. Control circuit not powered.</p> | <p>A. Check if the external main power switch is ON.</p> <p>B. Check if the unit main switch is ON.</p> <p>C. Check if the fuse is blown.</p> |
| 3 | Equipment Won't Start | <p>A. AC contactor not activated.</p> <p>B. Control board fault.</p> | <p>A. Check if the contactor coil is intact; check wiring from control board to contactor coil.</p> <p>B. Check if the corresponding I/O port voltage on the control board is normal.</p> |
| 4 | High Indoor Temperature | <p>A. Equipment not starting.</p> <p>B. Incorrect parameter settings.</p> <p>C. Airflow too low.</p> <p>D. Compressor not working.</p> <p>E. Control system not working.</p> | <p>A. See Fault 3.</p> <p>B. Check set parameters.</p> <p>C. See Fault 6.</p> <p>D. See Fault 11.</p> <p>E. Check system parameter settings.</p> |

| | | | |
|----|---|---|---|
| 5 | Low Indoor Temperature | A. Incorrect parameter settings. B. Heater not working (optional). | A. Check set parameters. B. Check system parameters, heater control, and power supply. |
| 6 | Low Airflow | A. Fan not powered. B. Air filter too dirty (filter dirty alarm). | A. Check fan wiring and fan motor. B. Clean/Replace filter; check if supply/return air ducts are unobstructed. |
| 7 | High Discharge Pressure | A. Insufficient outdoor unit condensation. B. Excessive refrigerant charge. C. High high-pressure, low low-pressure, hot discharge line. | A. Check condenser and ventilation; clean condenser. B. Release appropriate amount of refrigerant. C. Air or non-condensables in system, refrigerant impure; re-evacuate and recharge. |
| 8 | Low Discharge Pressure | A. Refrigerant leak. B. Outdoor fan control fault. | A. Check and repair leak, evacuate, and recharge refrigerant. B. Check if pressure controller is set/working correctly. |
| 9 | No Change in Suction/Discharge Pressure After Startup | A. Compressor reversed rotation or internal leakage. | A. If compressor rotation is reversed, swap any two L wires; if internal leakage, replace compressor. |
| 10 | Low Suction Pressure or Liquid Floodback | A. Drier filter blocked. B. Expansion valve malfunctioning. C. Air filter too dirty. D. Airflow too low. E. Room temperature too low. | A. Check temperatures before and after drier during cooling; replace drier filter. B. Adjust or replace expansion valve. C. Clean/Replace filter. D. Check return/supply airflow obstruction. E. See Fault 5. |
| 11 | Compressor Not Working | A. Compressor air switch tripped. | A. Check trip cause, reset air switch. B. Check compressor operating |

| | | | |
|----|------------------------|--|---|
| | | <p>B. Compressor thermal protection.</p> <p>C. Contactor not pulled in.</p> <p>D. High/Low pressure alarm not reset.</p> | <p>parameters.</p> <p>C. Check contactor coil and input power.</p> <p>D. Manually or automatically reset the alarm.</p> |
| 12 | Compressor Noisy | <p>A. Liquid floodback.</p> <p>B. Bearing wear due to oil loss.</p> <p>C. Loose or damaged compressor vibration dampers.</p> | <p>A. See Fault 10.</p> <p>B. Add lubricating oil.</p> <p>C. Adjust or replace mounting bolts, rubber vibration dampers.</p> |
| 13 | Compressor Overheating | <p>A. High compression ratio.</p> <p>B. High suction temperature.</p> | <p>A. Check high and low pressure switch settings, check if condenser is blocked, check all fans are running normally.</p> <p>B. Add appropriate amount of refrigerant.</p> |
| 14 | Sensor Alarm | <p>A. Sensor fault or poorly connected.</p> | <p>A. Check sensor wiring, reposition sensor, or replace sensor.</p> |
| 15 | Overvoltage | <p>A. Mains voltage higher than input voltage range.</p> | <p>A. Protection resets automatically after grid voltage recovers.</p> |
| 16 | Undervoltage | <p>A. Mains voltage lower than input voltage range.</p> | <p>A. Protection resets automatically after grid voltage recovers.</p> |
| 17 | Phase Sequence Error | <p>A. Incorrect three-phase power phase sequence.</p> | <p>A. Power down, swap phase sequence wiring, then repower.</p> |



Warning

The equipment has high voltage, so cut off the power supply before conducting internal maintenance. When the unit circuit breaker is turned off, the external power cable may be live.

9 System Maintenance

9.1 Overview

Preventive maintenance refers to the maintenance carried out at predetermined intervals or according to prescribed guidelines to reduce the probability of product failure or prevent functional degradation, mainly including adjustments, regular inspections, and necessary repairs. Familiarize equipment maintenance and operators with the performance, structural principles, usage methods, and precautions of the product, so that the equipment can perform its intended functions.

9.2 Preventive Maintenance

1) Operator Monitoring

Operators monitor the status of equipment during normal use, with the aim of identifying potential faults.

Once the operator discovers a system malfunction alarm, they should quickly conduct fault confirmation and inspection to find the cause of the malfunction.

2) Operational Inspection

During normal equipment operation, personnel shall perform periodic inspections according to schedule to determine if the product is performing its specified functions.

a) Inspect the gas and liquid pipelines, power cables, and other connections of the compressor and fluorine pump for integrity.

Inspection requirements: All pipelines and connections must be leak-free, and cables must be undamaged.

Inspection method: Visual check.

b) Inspect the liquid supply system and record data such as temperature and pressure every half day.

Inspection Requirement: Record the gas and liquid line temperatures and pressures of the compressor and fluorine pump. Observe if the data tends to stabilize during long-term operation.

Inspection Method: Visual check, data comparison.

c) Inspect the system for fault alarms (e.g., temperature, pressure), which are displayed on the "Fault Alarm Screen" of the touchscreen, and record them every half day.

Inspection Requirement: Troubleshoot system alarm points according to the instruction manual.

Inspection Method: Visual check, perform as needed.

d) After the machine is running normally, inspect the reliability of cable connections within the electrical cabinet and dry cooler junction box. This inspection is required for the first operation after installation or relocation, and subsequently every six months during normal operation.

Inspection Requirement: Check if cable connection points are tight and if there is any abnormal temperature rise.

Inspection Method: Visual check. Use a handheld infrared detector to check if the temperature at connection points is abnormal. If the displayed temperature exceeds 70°C or is 30°C higher than the ambient temperature, inspect and re-tighten the connection point.

9.3 Electrical Maintenance

Perform visual inspections and necessary actions on electrical connections according to the following items:

- 1) Overall Electrical Insulation Test: Locate and address any faulty contacts. During testing, ensure fuses or circuit breakers for the control section are disconnected to avoid high voltage damage to control components.
- 2) Statically check if each contactor engages flexibly without sticking or obstruction.
- 3) Remove dust from electrical and control components using a brush or dry compressed air.
- 4) Inspect contactor contacts for arcing marks or burning. Replace the corresponding contactor if severely damaged.
- 5) Tighten all electrical connection terminals.
- 6) Check if plug-in quick connectors have good contact. Replace terminals if looseness is found.

9.4 Control Maintenance

Perform visual inspections, simple functional checks, and necessary actions on the control section according to the following items:

1) Inspect the appearance of power transformers and isolation transformers, and measure their output voltages (including for indoor units and outdoor condensers).

2) Check control interface boards, display control boards, sensor boards, fuse holders, etc., for signs of significant aging.

3) Clean dust and dirt from electrical control components and control boards using a brush combined with electronic cleaning spray.

4) Check and secure all input/output plug connectors on the control interface board, including connections between the display control board and the control interface board, and between the control interface board and the temperature/humidity sensor board.

5) Check the connection between the user terminal block and the control interface board.

6) Check output connections from the control interface board to various contactors, and input connections from high/low pressure switches, heater overtemperature protection switches, filter clogging switches, and fan airflow safety switches. Pay special attention to plug-in terminals for high/low pressure switches and solenoid valves; replace them immediately if loose or making poor contact.

7) Replace faulty control fuses (or circuit breakers), control boards, and other electrical components found during inspection.

8) Check the specifications and aging condition of control or power wiring between the indoor unit and the condenser; replace the wiring if necessary.

9) Use a temperature and humidity measuring instrument with higher accuracy to check and calibrate the readings of the temperature and humidity sensors. Note: During the humidity sensor calibration process, ensure the humidity control mode is set to relative humidity control.



- Before tightening any assembly and electrical connections, ensure that the power supply to the control unit is switched off.;
- This sensor must not be used near flammable liquids or for detecting

Leak Detection Sensor (Water Sensor): The leak detection sensor contains a pair of dry contact switches. The switch closes when the sensor's probes detect water (or other conductive liquids). This sensor should be placed 1 to 2.5 meters away from the unit, away from damp drain traps or floor drains. It should not be installed directly under the unit.

9.5 Fan Assembly

Note: A ladder (2m) is required for maintenance.

Periodically inspect fan components, including the fan motor and impeller. Consult the manufacturer for more detailed information if needed.

1) Fan Impeller: Fans should be inspected periodically to ensure they are securely mounted to the fan shaft. Rotate the fan impeller to ensure it does not rub against the air guide ring.

2) Motor: When replacing a motor due to abnormal noise, burnout, or other failure, pay special attention to safety for top-airflow units. Use a special fixture to support the motor before removing the motor base mounting bolts.

3) Confirm the protective grille is not deformed.

4) Confirm there are no foreign objects inside the fan.

5) Confirm the blades are undamaged.

6) Confirm the mounting screws are not loose or deformed.

7) Confirm the wiring terminals are not loose.

9.6 Filter Maintenance

When a filter clogging alarm or filter maintenance time alarm appears, remove the filter for cleaning (with water) or replace it with a new one. Simultaneously, check if the filter is damaged or deformed, and replace it promptly if necessary.

Replacement Procedure: Disconnect the external power supply, open the unit's rear door, rotate the filter clamp 90 degrees, and then remove the filter.

9.7 Refrigeration System

Components of the refrigeration system must be inspected monthly to check for proper system function and signs of wear. As component failure or damage is often preceded by corresponding faults, regular inspection is the primary means of preventing most system failures. Refrigerant piping must have proper support and must not vibrate against ceilings, floors, or fixed structures. Check refrigerant piping every six months for wear or loosening of existing supports.

When a fault occurs in the refrigeration system, it can be diagnosed based on various operating parameters.

1) Expansion Valve

The automatic adjustment of the electronic expansion valve ensures the evaporator is supplied with sufficient refrigerant to meet load conditions. The operation of the expansion valve can be assessed by comparing the target exhaust temperature with the actual exhaust temperature.

Note: For systems equipped with electronic expansion valves, only check if the valve is

operating; manual adjustment is not required.

2) Outdoor Unit

Notes:

a) In heavy snow conditions, promptly clear snow from the outdoor unit fan, piping, electrical control box, and low-temperature components (if equipped).

b) For outdoor unit cleaning: Stop the machine, remove the wet media, connect a hose to a high-pressure water gun (pressure not too high), rinse the outdoor unit's fins, clean the wet media as well, and restart the unit after rinsing.

Routine Maintenance:

Unit Frame: Ensure it is securely connected to the ground; inspect at least every six months.

Refrigerant Piping: Perform the following checks on refrigerant piping at least monthly:

- a) Ensure piping is secure and reliable.
- b) Ensure all refrigerant piping is free from oil stains, frosting, or other abnormalities.
- c) Ensure pipe insulation is undamaged.

Condenser: Perform the following checks on the condenser at least monthly:

- a) Ensure fins are undamaged (e.g., no bent fins).
- b) Clean the condenser fins.
- c) Confirm unobstructed airflow into and out of the condenser.

Fan: Perform the following checks on the fan at least every six months:

- a) Ensure the junction box is undamaged and secure.
- b) Ensure the fan grille and air guide ring are not deformed, damaged, or interfering.
- c) Ensure the fan operates without abnormal noise, vibration, or impeller seizure.

3) Sight Glass

The state of refrigerant flow and gas/liquid content can be observed through the sight glass, facilitating maintenance and system optimization.

Sight Glass Maintenance Steps:

a) Check the sight glass. If the background color appears yellow, it indicates excessive moisture in the precision air conditioning refrigeration system, requiring maintenance.

b) If continuous bubbles are observed in the sight glass for an extended period, it indicates a lack of refrigerant in the system. Adjust the expansion valve or charge refrigerant as needed.

4) Compressor Replacement

Avoid skin contact with refrigerant and lubricating oil when replacing the compressor. Contact can cause severe burns or frostbite. Wear long-sleeved gloves when handling contaminated components.

The air conditioning system uses high-efficiency scroll compressors, which are highly reliable. If installation follows correct procedures strictly, the probability of failure during operation is very low.

Compressor motors rarely burn out due to insulation failure. In most cases where motors are burned out, it is caused by mechanical issues or poor lubrication leading to high-temperature overheating.

Most compressor failures can be avoided if potential problems are detected early and corrected. Regular maintenance checks by service personnel for abnormal operating conditions, and taking necessary steps to ensure proper system operation, are preferable to post-failure replacement. This approach is easier and much less costly.

When diagnosing a compressor, check if all its electrical components are operating normally:

a) Check all fuses and circuit breakers.

b) Check the operation of high and low pressure switches. Determine if the compressor failure is due to an electrical or mechanical fault.

Mechanical Failure: Mechanical failure cannot be identified by smelling for burning. Attempt to turn the motor. If mechanical failure is confirmed, the compressor must be replaced. If the motor is burned out, correct the cause and clean the system. Note that compressor motor burnout is often caused by improper system cleanliness.

Electrical Failure: Electrical failure can be identified by a distinct pungent odor. In severe burnout cases, the lubricating oil turns black and becomes acidic. In cases of electrical failure and complete burnout of the refrigeration compressor motor, measures must be taken to clean the system to remove acidity and prevent future occurrences.

Damage to replacement compressors due to improper cleaning is considered misuse under warranty terms and is not covered. When a compressor is completely burned out, replace the compressor and the drier filter simultaneously. Also, inspect the expansion valve and replace it if faulty. System cleaning is mandatory before replacement. If the cleaning method is unclear, consult our professional technical personnel.

Compressor Replacement Procedure:

1. Cut off the power supply.
2. Connect the low and high-pressure gauges to the service ports on the suction and discharge lines respectively, and recover the refrigerant.
3. Disconnect the electrical connections to the compressor.
4. Unbrazed the suction and discharge pipes from the unit.
5. Remove the faulty compressor.
6. If the compressor was completely burned out, clean the refrigerant circuit and replace the drier filter.
7. Install the new compressor in position, connect the piping, and reconnect the electrical wiring.
8. Evacuate the system and add refrigerant according to the commissioning specifications.
9. Power on the system following the normal startup and commissioning procedure. Check if the system operating parameters are normal. Observe the refrigerant state through the sight glass, and determine the refrigerant charge amount based on system pressure and temperature parameters until the system operates normally.



- Refrigerant must be recovered or disposed of in accordance with relevant regulations. Releasing refrigerant into the atmosphere is harmful to the environment and illegal.;
- Do not remove the rubber plugs from the suction and discharge ports of a new replacement compressor too early. After removing the plugs, the ports should not remain exposed to air for more than 15 minutes to prevent the

10 Safety Instructions



- If the equipment remains out of service for an extended period, the main power switch should be turned off. After a prolonged power outage, the standard

10.1 Maintenance

Only qualified and authorized personnel are allowed to carry out maintenance and other operations on the electrical system.

10.2 Operation

Before starting the cooling system inside the container, a fire extinguisher should be equipped.

- 1) The equipment must have at least two reliable grounding positions, and the protective grounding resistance should be verified to ensure continuity. Its value should be less than 0.1Ω , otherwise there may be a dangerous situation that may cause personal injury or death.
- 2) Only clean the equipment after shutting down and turning off the power, otherwise it may cause electric shock or injury. Do not use water to clean the equipment, otherwise it may cause electric shock.
- 3) Before starting the machine, be sure to check if the valve (if present) is open.
- 4) Safety regulations for the operation of power distribution cabinets and main control cabinets:
 - a. Before operating the power cabinet A/B, it is necessary to ensure that the cabinet door is locked to prevent personal injury such as electric shock, and to prevent salt mist, moisture, dust or other conductive substances from entering the interior of power cabinets;
 - b. When powering on, it is prohibited to touch the single board, cables, terminals, modules, sensors and other equipment inside the cabinet to avoid safety accidents;
 - c. If there is a malfunction, odor, or abnormal sound, please close the main switches of the system, or press the emergency stop button on the front door, otherwise it may cause electric shock or fire accidents.

10.3 Attention

- 1) Nonprofessional authorized personnel are prohibited from opening the door of the distribution cabinet.
- 2) Only when the main switch is in the OFF position can the distribution cabinet door be opened.
- 3) Before using this equipment, please read this manual carefully. If you have any difficulties or problems, please consult authorized personnel from the factory for assistance.

 **Danger**

The main circuit breaker is in the OFF position, and the front end of the main circuit breaker is live. Unauthorized and professional personnel are prohibited from opening the protective board.